



Gearbox Catalogue 2016
Issue 1



01299 252990



01299 253597

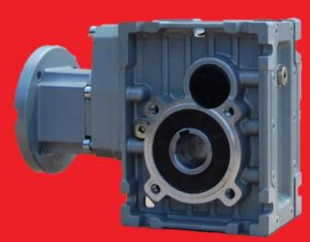

www.tecmotors.co.uk

TEC ELECTRIC MOTORS - GEARBOX DIVISION

2010 saw the introduction of the industrial gearbox division. We initially stocked a range of worm gear reducers providing interchangeability with most of our competitors.

During 2011 TEC secured a deal to become the official UK distributor for Varvel products.

Now with substantial stocks of geared units, we continue to increase our inventory and product range capabilities, with a recent introduction of helical in-line and bevel helical units. Products up to 8000 Nm are now available in the UK, but much larger units can be supplied in competitive lead times.

The information contained in this catalogue is in a short form style and is intended to make it user friendly, but still include all the useful data required on a daily basis.

More detailed information about our products can be found on our website.

Component products are held in stock to enable quick build and supply of helical in-line and bevel-helical gearboxes. We also specialise in building non-catalogue combinations from stock.

Tec's strategy is to provide a "one stop shop" for all power transmission products, offering a level of service unequalled by our competitors.

TEC = Total Engineering Commitment



Company Profile

Company Information:

TEC Electric Motors were formed following a management buyout of the former TEE Distribution Company.

Year formed: 2005

Number of staff: 42

HQ location: Worcestershire

Turnover: £16 million

Main markets: HVAC, Conveyor, Pump, Hydraulic, Offshore, Distribution.

Products:

- 2/4/6/8/10/12 pole motors
- 56-355 frame
- Multi mount 56-200 aluminium
- Multi mount 80-280 cast iron
- Fixed feet 315-355 cast iron
- IE1, IE2, IE3 efficiency rated
- IE3 motors ECA approved
- Increased output IE1 and IE2
- 1 phase motors 56-112 frame
- 1 phase motors 230/110 Volt
- 60Hz 1ph motors also available
- ATEX EExde Zone 1, 71-355 frame
- ATEX Zone 2/22, 56-355 frame
- ATEX Zone 21 & ATEX single phase
- Brake motors 63-315 frame
- Two speed, dual & tap wound
- Special Voltages & shafts etc.
- Full Vector motors
- Force ventilation fan kits
- Right angle worm gearboxes
- Helical in-line gearboxes
- Right angle bevel helical gearboxes
- Mechanical speed variators
- Special combination low speed units
- Inverters - IP20, 31 & 65
- KVA & mW (Mega Watt) motors

Introduction	Company Profile	
Section 1	General Information	2
Section 2	Worm Gearbox - FCNDK	
	Gearbox Types	3
	Parts list, Mounting Positions and Lubrication	4
	Performance	5
	Dimensions	7
	Accessories Dimensions	8
	Double Reduction Worm Gearbox Performance	9
	Double Reduction Worm Gearbox Dimensions	10
	Helical Worm Gearbox	11
	Helical Worm Gearbox Performance	12
Section 3	Mechanical Variators - MB	
	Parts list, Mounting Positions and Lubrication	13
	Dimensions and Performance	14
Section 4	Varvel	
	Gearbox Types	15
	Flexible Input Coupling 'G'	16
	RD Helical In-line Parts list, Mounting and Lubrication	17
	RD Helical In-line Performance	18
	RD Helical In-line Dimensions	20
	Worm Gearbox Types	22
	RS/RT Worm Gearbox Performance	23
	RS/RT Worm Gearbox Dimensions	24
Section 5	Bevel Helical Gearbox TKM	
	Gearbox Types	26
	Parts list, Mounting Positions and Lubrication	27
	Performance	28
	Dimensions	30
	Accessories Dimensions	31
Section 6	Bevel Helical Gearbox WK	
	Gearbox Types	32
	Parts list, Mounting Positions and Lubrication	33
	Performance	34
	Dimensions	36
Section 7	Helical In-line Gearbox WR	
	Gearbox Types	38
	Parts list, Mounting Positions and Lubrication	39
	Performance	40
	Dimensions	42
Section 8	Motors	
	Dimensions, Terminal Box Positions	43

Service Factors Explained

All the performance figures quoted in this catalogue are based on the following information.
 Service factor (f_s) 1.0 equates to 8 hours per day operation, uniform load, mass acceleration factor $f_a \leq 0.2$, start/stops less than 300 per hour and ambient temperature between 15 and 35° Celsius.

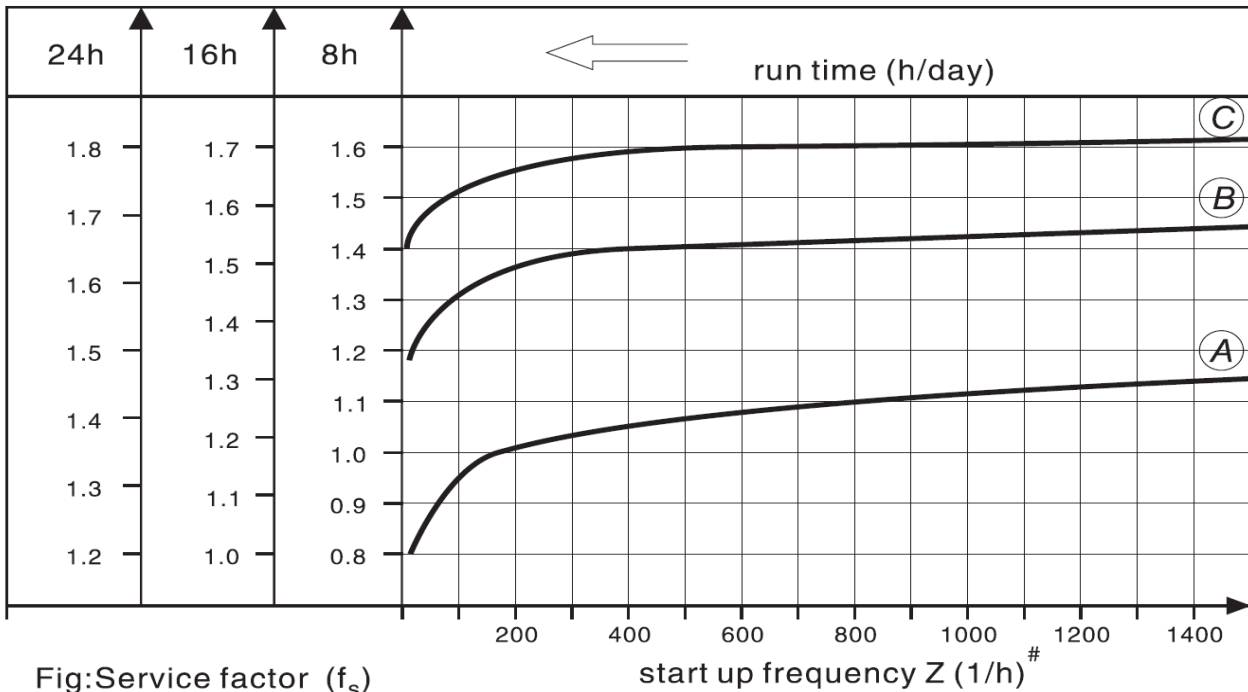

Fig: Service factor (f_s)

start up frequency Z (1/h)[#]

Please note for worm gearboxes this figure should be approximately 5%

Example: Page 5, **FCNDK63 ratio 20:1**. Service factor 1 = 1.2 KW, so if fitting a 1.1KW motor $SF = 1.2/1.1 = 1.09$. If fitting a 1.5KW motor $SF = 1.2/1.5 = 0.8$.

Load Classification

- (A)** Uniform, permitted mass acceleration $f_a \leq 0.2$
- (B)** Moderate shock load, permitted mass acceleration $f_a \leq 3$
- (C)** Heavy shock load, permitted mass acceleration $f_a \leq 10$

$$f_a = J_e / J_m$$

f_a , factor of inertia

J_e , (kgm^2) all external mass moment of inertia

J_m , (kgm^2) moment of inertia of motor

A - Screw feeders for light materials, fans, assembly lines, conveyor belts for light materials, small mixers, lifts, cleaning machines, fillers, control machines.

B - Winding devices, woodworking machine feeders, goods lifts, balancers, threading machines, medium mixers, conveyor belts for heavy materials, winches, sliding doors, fertilizer scrapers, packing machines, concrete mixers, crane mechanisms, milling cutters, folding machines, gear pumps.

C - Mixers for heavy materials, shears, presses, centrifuges, rotating supports, winches and lifts for heavy materials, grinding lathes, bucket elevators, drilling machines, hammer mills, turntables, tumbling barrels, vibrators, cam presses, stone mills, folding machines, shredders.

Key to symbols used in this catalogue

n_1 = input speed, n_2 = output speed, kW = input power, M2 = output torque,
 Fr_2 = max radial load on output shaft.



FCNDK - MOTOR READY



FCNK - REDUCER



FCNDK - DOUBLE REDUCTION



FCNK - DOUBLE REDUCTION REDUCER



FCNDK/FXA - HELICAL WORM



FCNDK/MB.. - VARIABLE-SPEED

Section 2 TEC FCNDK Worm Gearbox

Summary

FCNDK series worm gear units have been designed based on the modular format system. All types of IEC motors can be fitted. More details of TEC motors can be found in our separate catalogue. The versatility of the design lends itself to all types of mounting. All sizes in this range, apart from size **150**, are supplied filled with synthetic long-life oil grade ISO VG 320. Housings for sizes 25-90 are aluminium, sizes 110-150 are cast iron.

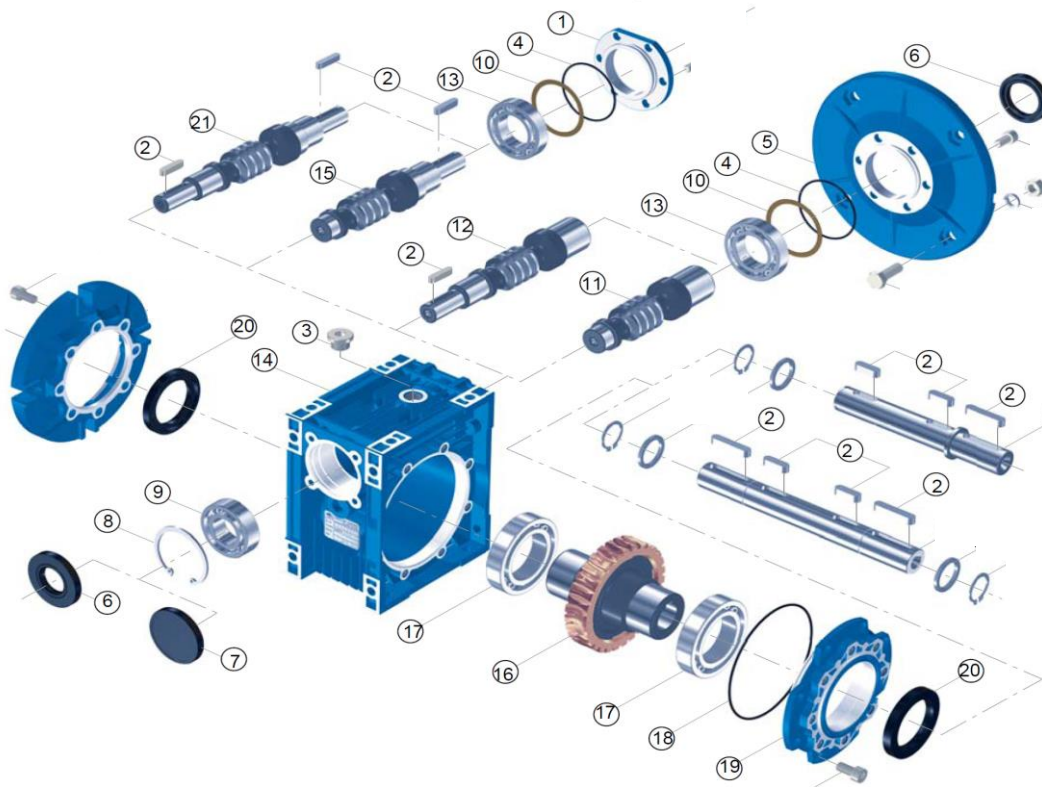

No.	Description
1	Input cover
2	Key
3	Filler plug-breather
4	O-ring (input)
5	Input flange
6	Oil seal
7	Oil seal RCA
8	Circlip
9	Bearing
10	Shim
11	Worm hollow input
12	Worm extended
13	Bearing
14	Housing
15	Worm solid input
16	Worm wheel
17	Bearing
18	O-ring (output)
19	Bearing cover
20	Oil seal
21	Worm d/extended

Mounting positions

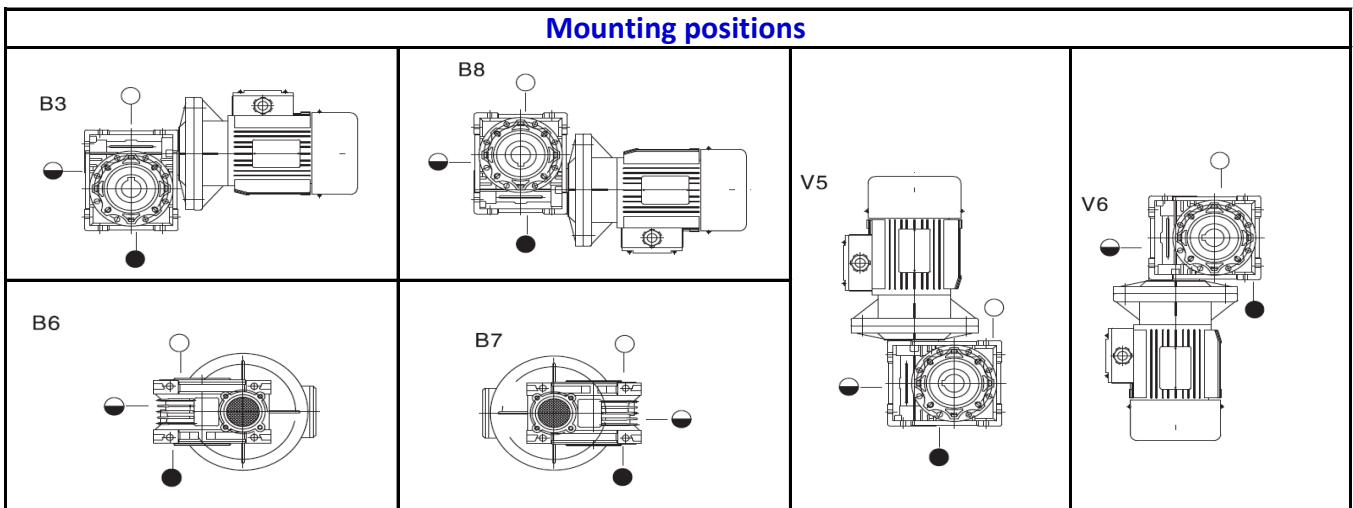

Sizes 25-90 do not require breather plug. Sizes 110-150 supplied with breather.

Oil fill quantity in litres

Mtg	25	30	40	50	63	75	90	110	130	150
B3	0.02	0.04	0.08	0.15	0.3	0.55	1.0	2.0	3.0	5.5
B6-7								1.7	2.8	5.0
B8								1.7	2.8	4.5
V5								2.0	3.0	5.5
V6								2.0	3.0	5.5

Section 2 TEC FCNDK Worm Gearbox

Performance (n₁ with 4 pole 1400 rpm motor, sf = 1)

Size	Ratio	n ₂ (rpm)	kW	M ₂ (Nm)	F _{r2} (N)	Motor input options			
						56B14			
FCNDK25	7.5	187	0.25	11	503				
	10	140	0.22	12	553				
	15	93	0.14	11	633				
	20	70	0.12	12	697				
	30	46	0.10	13	798				
	40	35	0.80	13	878				
	50	28	0.06	11	946				
						56B14	56B5	63B14	63B5
FCNDK30	5	280	0.65	18	654				
	7.5	187	0.41	18	683				
	10	140	0.32	18	752				
	15	93	0.23	18	861				
	20	70	0.18	18	948				
	25	56	0.18	20	1021				
	30	46	0.18	20	1085				
	40	35	0.11	18	1194				
	50	28	0.09	17	1286				
60	23	0.08	16	1367					
80	17	0.05	12	1504					
						56B5	63B14	63B5	71B14-B5
FCNDK40	5	280	1.10	34	1149				
	7.5	187	0.90	40	1315				
	10	140	0.69	40	1447				
	15	93	0.48	39	1657				
	20	70	0.37	39	1824				
	25	56	0.30	38	1964				
	30	46	0.31	44	2087				
	40	35	0.23	41	2298				
	50	28	0.18	37	2475				
	60	23	0.15	35	2630				
	80	17	0.12	33	2895				
100	14	0.09	29	3118					
						63B14-B5	71B14-B5	80B14	80B5
FCNDK50	5	280	2.00	62	1736				
	7.5	187	1.60	71	1805				
	10	140	1.20	70	1987				
	15	93	0.88	73	2274				
	20	70	0.68	72	2503				
	25	56	0.54	69	2696				
	30	46	0.57	83	2865				
	40	35	0.42	77	3153				
	50	28	0.34	73	3397				
	60	23	0.28	68	3610				
	80	17	0.22	64	3973				
100	14	0.16	52	4280					
						71B14	71B5	80B14-B5	90B14-B5
FCNDK63	7.5	187	2.80	126	2359				
	10	140	2.20	129	2597				
	15	93	1.60	134	2973				
	20	70	1.20	131	3272				
	25	56	1.00	131	3524				
	30	46	1.10	164	3745				
	40	35	0.76	143	4122				
	50	28	0.60	133	4440				
	60	23	0.51	130	4719				
	80	17	0.39	119	5193				
	100	14	0.34	118	5595				

	Standard option
	Not possible
	Possible using shaft reducing sleeve

Section 2 TEC FCNDK Worm Gearbox

Performance (n₁ with 4 pole 1400 rpm motor, sf = 1)

Size	Ratio	n ₂ (rpm)	kW	M ₂ (Nm)	F _{r2} (N)	Motor input options			
						71B5	80B14-B5	90B14-B5	100B14-B5
FCNDK75	7.5	187	4.1	185	2785				
	10	140	3.2	190	3065				
	15	93	2.3	198	3509				
	20	70	1.9	210	3862				
	25	56	1.5	202	4160				
	30	46	1.5	233	4421				
	40	35	1.1	216	4865				
	50	28	0.9	206	5241				
	60	23	0.75	197	5569				
80	17	0.58	187	6130					
100	14	0.48	180	6603					
						80B14-B5	90B14-B5	100B14-B5	112B14-B5
FCNDK90	7.5	187	6.3	287	3081				
	10	140	5.1	306	3391				
	15	93	4.1	357	3882				
	20	70	3.1	361	4273				
	25	56	2.4	332	4603				
	30	46	2.6	415	4891				
	40	35	1.8	363	5383				
	50	28	1.4	339	5799				
	60	23	1.1	307	6163				
80	17	0.83	285	6783					
100	14	0.67	270	7306					
						90B14-B5	100B14-B5	112B14-B5	132B14-B5
FCNDK110	7.5	187	12.0	541	3893				
	10	140	9.8	586	4285				
	15	93	7.5	643	4905				
	20	70	5.6	631	5399				
	25	56	4.7	665	5816				
	30	46	4.5	710	6181				
	40	35	3.3	688	6803				
	50	28	2.6	647	7328				
	60	23	2.1	604	7787				
80	17	1.4	505	8571					
100	14	1.1	473	9232					
						90B5	100B14-B5	112B14-B5	132B14-B5
FCNDK130	7.5	187	16.1	735	5092				
	10	140	13.5	804	5605				
	15	93	10.3	900	6416				
	20	70	7.8	892	7062				
	25	56	6.5	910	7607				
	30	46	6.4	1020	8084				
	40	35	4.9	1030	8897				
	50	28	3.8	960	9584				
	60	23	3.1	880	10185				
80	17	2.3	825	11210					
100	14	1.7	725	12076					
						100B5	112B5	132B5	160B5
FCNDK150	7.5	187	25.8	1175	6962				
	10	140	20.2	1215	7663				
	15	93	13.9	1225	8771				
	20	70	11.1	1275	9654				
	25	56	8.4	1175	10400				
	30	46	7.1	1175	11051				
	40	35	7.3	1520	12163				
	50	28	5.4	1370	13103				
	60	23	4.2	1235	13924				
80	17	3.1	1130	15325					
100	14	2.3	980	16508					

Standard option
 Not possible
 Possible using shaft reducing sleeve

Installation - Dimensions

FCNK

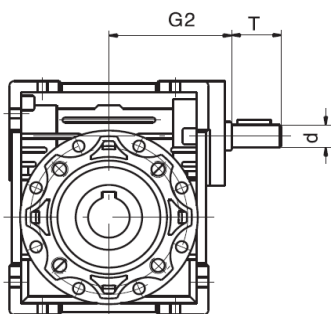

FCNDK

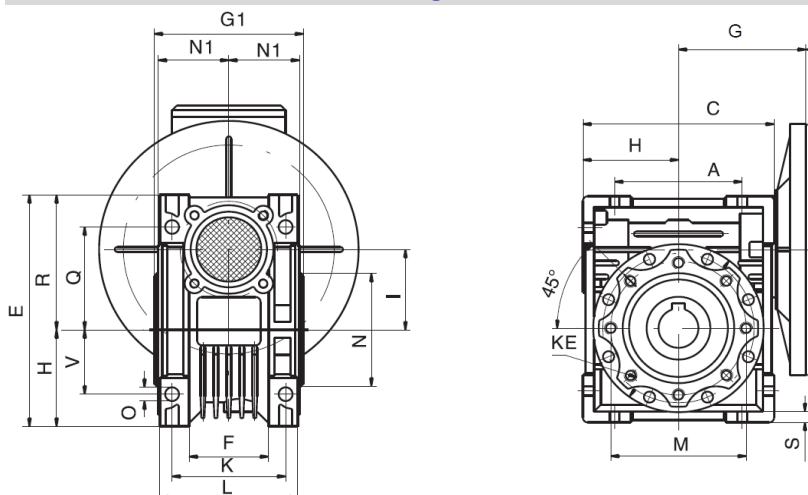

Output Hub

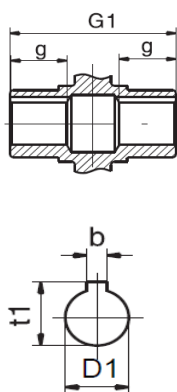

Input Flange

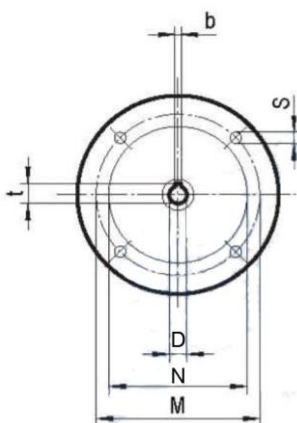

Input Motor Flange Dimensions

Ref	D	P	M	N	b	s	t
56B14	9	80	65	50	3	5	10.4
56B5	9	120	100	80	3	7	10.4
63B14	11	90	75	60	4	9	12.8
63B5	11	140	115	95	4	9	12.8
71B14	14	105	85	70	5	7	16.3
71B5	14	160	130	110	5	9	16.3
80B14	19	120	100	80	6	7	21.8
80B5	19	200	165	130	6	11	21.8
90B14	24	140	115	95	8	9	27.3
90B5	24	200	165	130	8	11	27.3
100-112B14	28	160	130	110	8	9	31.3
100-112B5	28	250	215	180	8	13.5	31.3
132B14	38	200	165	130	10	11	41.3
132B5	38	300	265	230	10	13.5	41.3
160B5	42	350	300	250	12	17	45.3

Size	Dimensions																			
	A	C	D1*	E	F	G _{max}	H	I	L	M	N(h8)	O	Q	R	S	T	V	K	G1	G2
25	45	70	11	83	22	45	35	25	45	55.0	45	6.0	35.5	48	5		22.5	34.0	50	
30	54	80	14	97	32	55	40	30	56	65	55	6.5	44	57	5.5	20	27	44	63	51
40	70	101	18	122	43	69	50	40	71	75	60	6.5	55	72	6.5	23	35	60	78	60
50	80	122	25	144	49	90	60	50	85	85	70	8.5	64	85	7	30	40	70	92	74
63	100	148	25	174	67	106	72	63	103	95	80	8.5	80	102	8	40	50	85	112	90
75	120	174	28	205	72	121	86	75	113	115	95	11	93	119	10	50	60	90	120	105
90	140	208	35	238	72	138	103	90	130	130	110	13	102	135	11	50	70	100	140	125
110	170	253	42	295		159	128	110	142	165	130	14	125	167	15	60	85	115	155	142
130	200	293	45	335		179	148	130	155	215	180	16	140	188	15	80	100	120	170	162
150	240	340	50	400		212	170	150	185	215	180	18	180	230	18	80	120	145	200	210

Size	g	N1	KE	d (j6)	b	t1	weight (kg)
25		22.5	6.5				0.7
30	20	29	M6x11(n4)	9	5	16.3	1.2
40	23	36.5	M6x8 (n4)	11	6	20.8	2.3
50	30	43.5	M8x10(n4)	14	8	28.3	3.5
63	40	53	M8x14(n8)	19	8	28.3	6.2
75	40	57	M8x14(n8)	24	8	31.3	9.0
90	45	67	M10x18(n8)	24	10	38.3	13.0
110	50	74	M10x18(n8)	28	12	45.3	35.0
130	60	81	M12x20(n8)	30	14	48.8	48.0
150	70	96	M12x21(n8)	35	14	53.8	84.0

Size	D1 Bore options (H7)					
	D1	b	t1	D1	b	t1
40	19	6	21.8			
50	24	8	28.3			
63	28	8	31.3	30	8	33.3
75	30	8	33.3	35	10.0	38.3
90	38	10	41.2	40	12.0	43.3

Accessories - Dimensions

Output Flange Dimensions									
Size	Ref	KA	KP	KM	KN	KQ	KB	KC	KO
FCNDK25	FA	45	75	55	40	70	6	2.5	6.5x4
FCNDK30	FA	55	80	68	50	70	6	4	6.5x4
FCNDK40	FA	67	110	75	60	95	7	4	9x4
	FB	97	110	75	60	95	7	4	9x4
	FC	80	140	115	95	126	9	5	9.5x4
	FD	58	120	100	80	110	12	5	9x4
FCNDK50	FA	90	125	90	70	110	9	5	11x4
	FB	120	125	90	70	110	9	5	11x4
	FC	89	160	130	110	146	10	5	9.5x4
	FD	72	140	115	95	130	14.5	5	11x4
FCNDK63	FA	82	180	150	115	142	10	6	11x4
	FB	112	180	150	115	142	10	6	11x4
	FC	98	200	165	130	180	10	5	11x4
FCNDK75	FA	107	200	165	130	180	10	5	11x4
	FB	111	200	165	130	170	13	6	14x4
	FC	90	160	130	110	160	13	6	11x4
FCNDK90	FA	111	210	175	152	200	13	6	14x4
	FB	122	250	215	180	230	18	6	14x4
	FC	110	200	165	130	200	17	6	11x4
	FD	151	210	175	152	200	13	6	14x4
FCNDK110	FA	139	270	220	170	250	15	6	14x4
FCNDK130	FA	152	320	255	180	290	15	6	16x8
FCNDK150	FA	155	320	255	180	290	15	7	16x8

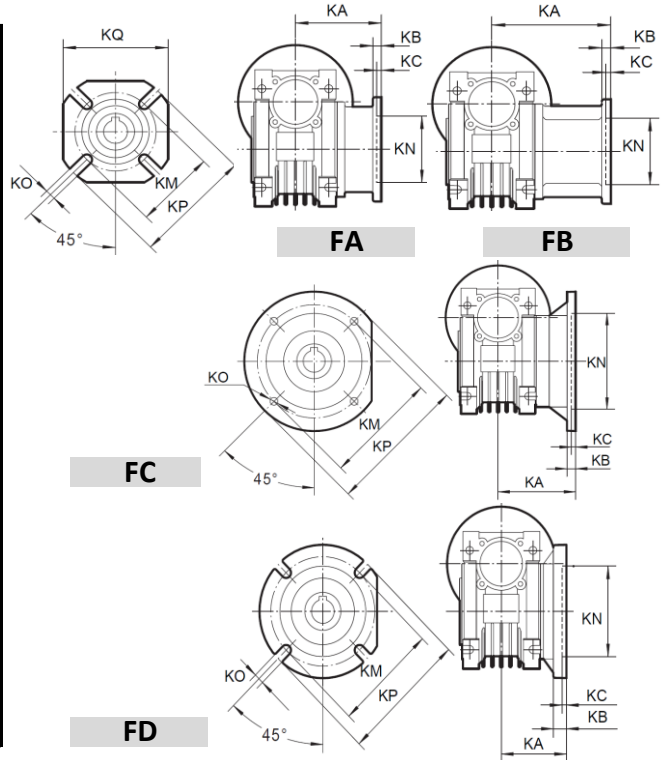

Single-Double Output Shaft								
Size	D(h6)	B	B1	L	L1	f	b	t
25	11	23	25.5	81	101		4	12.5
30	14	30	32.5	102	128	M6	5	16
40	18	40	43.0	128	164	M6	6	20.5
50	25	50	53.5	153	199	M10	8	28
63	25	50	53.5	173	219	M10	8	28
75	28	60	63.5	192	247	M10	8	31
90	35	80	84.0	234	308	M12	10	38
110	42	80	84.5	249	324	M16	12	45.0
130	45	80	85.0	265	340	M16	14	48.5
150	50	102	110	324	420	M20	14	53.5

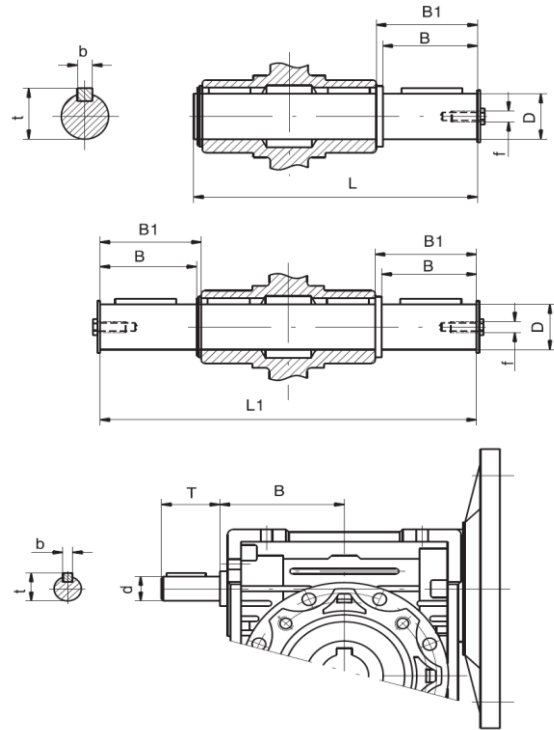

Extended Worm Shafts					
Size	B	d(h6)	T	b	t
25	38	9	18	3	10.2
30	45	9	20	3	10.2
40	53	11	23	4	12.5
50	64	14	30	5	16
63	75	19	40	6	21.5
75	90	24	50	8	27
90	108	24	50	8	27
110	135	28	60	8	31
130	155	30	80	8	33
150	210	35	80	10	38

Torque Arms								
Size	A	B	C	D	E	F	G	H
25	70	33	118	45	55	7	14	8
30	85	38	138	54	65	7	14	8
40	100	44	162	60	75	7	14	10
50	100	50	168	70	85	9	14	10
63	150	55	223	80	95	9	14	10
75	200	70	300	95	115	9	25	20
90	200	80	310	110	130	11	25	20
110	250	100	385	130	165	11	30	25
130	250	125	410	180	215	14	30	25
150	250	125	410	180	215	14	30	25

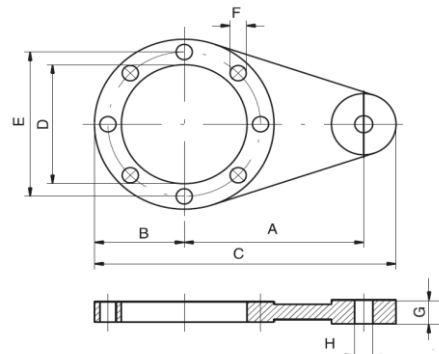

Section 2 TEC FCNDK Double Reduction Worm Gearbox

Performance (n1 with 4 pole 1400 rpm motor, sf = 1)

Size	i	n2	KW1	M2	i1	i2
FCNDK25/40	300	4.7	0.06	59	10	30
	400	3.5	0.06	63	10	40
	500	2.8	0.04	57	20	25
	600	2.3	0.04	65	20	30
	750	1.9	0.04	60	30	25
	900	1.6	0.03	73	30	30
	1200	1.2	0.02	65	40	30
	1500	0.9	0.02	60	50	30
	1800	0.8	0.02	56	30	60
	2400	0.58	0.01	60	40	60
	3200	0.44	0.01	65	40	80
	4000	0.35	0.01	32	50	80
5000	0.28	0.01	28	50	100	

Size	i	n2	KW1	M2	i1	i2
FCNDK40/75	300	4.7	0.36	390	10	30
	400	3.5	0.27	360	10	40
	500	2.8	0.21	320	10	50
	600	2.3	0.19	390	20	30
	750	1.9	0.16	390	25	30
	900	1.6	0.14	390	30	30
	1200	1.2	0.11	360	40	30
	1500	0.9	0.10	390	50	30
	1800	0.8	0.09	360	60	30
	2400	0.58	0.07	360	60	40
	3000	0.47	0.05	320	60	50
	4000	0.35	0.04	250	80	50
5000	0.28	0.03	230	100	50	

FCNDK30/40	300	4.7	0.08	73	10	30
	400	3.5	0.06	65	10	40
	500	2.8	0.04	61	20	25
	600	2.3	0.04	73	20	30
	750	1.9	0.04	73	25	30
	900	1.6	0.03	73	30	30
	1200	1.2	0.02	65	40	30
	1500	0.9	0.02	73	50	30
	1800	0.8	0.02	73	60	30
	2400	0.58	0.01	65	60	40
	3200	0.44	0.01	65	80	40
	4000	0.35	0.01	33	80	50
5000	0.28	0.01	29	100	50	

FCNDK40/90	300	4.7	0.56	610	10	30
	400	3.5	0.43	610	10	40
	500	2.8	0.34	560	10	50
	600	2.3	0.30	610	20	30
	750	1.9	0.23	560	25	30
	900	1.6	0.19	505	30	30
	1200	1.2	0.17	610	40	30
	1500	0.9	0.14	560	50	30
	1800	0.8	0.11	505	60	30
	2400	0.58	0.11	610	60	40
	3000	0.47	0.08	560	60	50
	4000	0.35	0.08	460	80	50
5000	0.28	0.06	410	100	50	

FCNDK30/50	300	4.7	0.15	145	10	30
	400	3.5	0.10	124	10	40
	500	2.8	0.09	120	10	50
	600	2.3	0.08	145	20	30
	750	1.9	0.07	145	25	30
	900	1.6	0.06	145	30	30
	1200	1.2	0.04	124	40	30
	1500	0.9	0.04	145	50	30
	1800	0.8	0.04	145	60	30
	2400	0.58	0.03	124	60	40
	3000	0.47	0.02	120	60	50
	4000	0.35	0.02	82	80	50
4800	0.29	0.02	82	80	60	

FCNDK50/110	300	4.7	1.10	1265	10	30
	400	3.5	0.80	1185	10	40
	500	2.8	0.54	1100	10	50
	600	2.3	0.59	1185	20	30
	750	1.9	0.56	1265	25	30
	900	1.6	0.50	1265	30	30
	1200	1.2	0.38	1185	40	30
	1500	0.9	0.34	1265	50	30
	1800	0.8	0.31	1265	60	30
	2400	0.58	0.22	1185	60	40
	3000	0.47	0.18	1100	60	50
	4000	0.35	0.11	819	80	50
5000	0.28	0.09	746	100	50	

FCNDK30/63	300	4.7	0.24	230	10	30
	400	3.5	0.19	230	10	40
	500	2.8	0.15	216	10	50
	600	2.3	0.13	230	20	30
	750	1.9	0.11	216	25	30
	900	1.6	0.09	198	30	30
	1200	1.2	0.08	230	40	30
	1500	0.9	0.06	216	50	30
	1800	0.8	0.05	198	60	30
	2400	0.58	0.05	230	60	40
	3000	0.47	0.04	216	60	50
	4000	0.35	0.03	172	80	50
5000	0.28	0.02	150	100	50	

FCNDK63/130	300	4.7	1.48	1760	10	30
	400	3.5	1.09	1650	10	40
	500	2.8	0.86	1550	10	50
	600	2.3	0.76	1650	20	30
	750	1.9	0.66	1760	25	30
	900	1.6	0.58	1760	30	30
	1200	1.2	0.43	1650	40	30
	1500	0.9	0.39	1760	50	30
	1800	0.8	0.35	1760	60	30
	2400	0.58	0.25	1650	60	40
	3000	0.47	0.20	1550	60	50
	4000	0.35	0.15	1220	80	50
5000	0.28	0.11	1100	100	50	

Installation - Dimensions

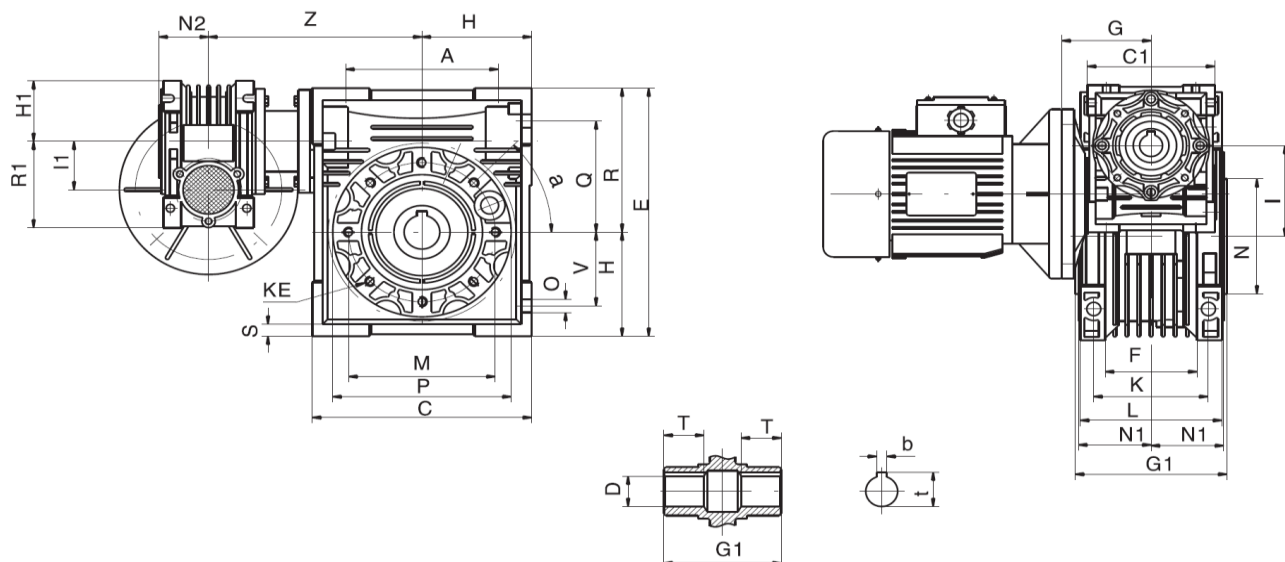

Size	25/30	25/40	30/40	30/50	30/63	40/75	40/90	50/110	63/130	63/150
A	54	70	70	80	100	120	140	170	200	240
a	0	45°	45°	45°	45°	45°	45°	45°	45°	45°
b	5	6	6	8	8	8	10	12	14	14
C	80	100	100	120	144	172	206	252.5	292.5	340
C1	70	70	80	80	80	101	101	122	148	148
D (H8)	14	18	18	25	25	28	35	42	45	50
E	97	121.5	121.5	145	174	205	238	295	335	400
F	32	43	43	49	67	72	74			
G	45	45	55	55	55	70	70	80	95	95
G1	63	78	78	92	112	120	140	155	170	200
H	40	50	50	60	72	86	103	128	148	170
H1	35	35	40	40	40	50	50	60	72	72
I	30	40	40	50	63	75	90	110	130	150
I1	25	25	30	30	30	40	40	50	63	63
K	44	60	60	70	85	90	100	115	120	145
KE	M6x11 n.4	M6x8 n.4	M6x8 n.4	M8x10n.8	M8x14n.8	M8x14n.8	M10x18n.8	M10x18n.8	M12x12n.8	M12x12n.8
L	56	71	71	85	103	112	130	144	155	185
M	65	75	75	85	95	115	130	165	215	215
N (h8)	54	60	60	70	80	95	110	130	180	180
N1	28	35.5	35.5	42.5	51.5	56.5	65	71	77.5	92.5
N2	22.5	22.5	28	28	28	35.5	35.5	42.5	51.5	51.5
O	6.5	6.5	6.5	8.5	8.5	11	13	14	16	18
P	75	87	87	100	110	140	160	200	250	250
Q	44	55	55	64	80	93	102	125	140	180
R	57	71.5	71.5	84	102	119	135	167.5	187.5	230
R1	48	48	57	57	57	71.5	71.5	84	102	102
S	5.5	6.5	6.5	7	8	10	11	14	15	18
T	20	23	26	30	40	40	45	50	60	70
t	16.3	20.8	20.8	28.3	28.3	31.3	38.3	45.3	48.8	53.8
V	27	35	35	40	50	60	70	85	100	120
Z	100	115	122	132	145	167.5	184.5	226	245	270
Wt (Kg)	2.1	3.2	3.9	5	7.7	12	16	39.2	55	91



Summary

The helical gearboxes series FXA are manufactured as follows: aluminium die cast housing and covers, helical gears in alloy steel, case hardened, tempered and shaved. Gears - designed and verified according to ISO 6336 and DIN 3990 - and bearings are calculated for at least 15,000 running hour average life-time (assuming SF=1). Keyways according to DIN 6884.

Dimensions

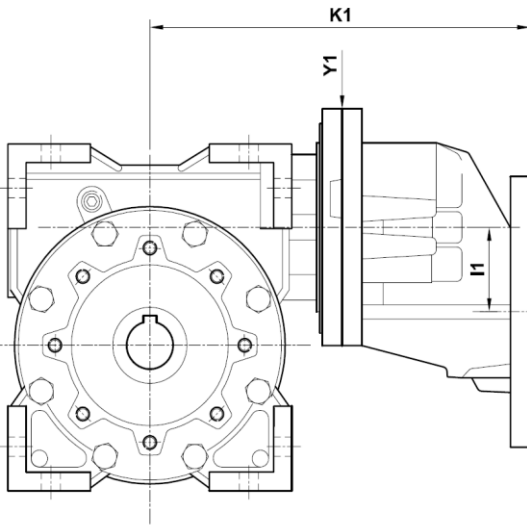

Size	I1	K1	Y1	Wt (kg)
FCNDK40/FXA63	32	153	105	3.8
FCNDK50/FXA63	32	163	105	5.0
FCNDK50/FXA71	40	170	120	5.7
FCNDK63/FXA63	32	178	105	7.7
FCNDK63/FXA71	40	185	120	8.4
FCNDK63/FXA80	50	209	140	9.2
FCNDK75/FXA71	40	203	120	11.2
FCNDK75/FXA80	50	227	140	12.0
FCNDK90/FXA71	40	220	120	15.2
FCNDK90/FXA80	50	244	140	16.0
FCNDK110/FXA80	50	274	140	38.0
FCNDK110/FXA100	63	337	200	42.0
FCNDK130/FXA100	63	357	200	55.0

Size	Performance			Motor Input Options					
	Ratio	KW	Nm	56B14-B5	63B14-B5	71B14-B5	80B14-B5	90B14-B5	100B14-B5
FXA63	3.53	0.50	12						
	6.18	0.23	10						
	7.77	0.18	9						
FXA71	3.53	1.10	26						
	6.40	0.52	22						
	8.00	0.37	20						
FXA80	3.42	3.10	68						
	6.40	1.50	65						
	8.30	1.10	60						
FXA100	3.88	8.70	235						
	6.23	4.00	163						
	8.40	2.20	136						

The FXA gearboxes are delivered filled With synthetic long-life oil (without plugs) and in the appropriate quantity to install them in any mounting position without prior specification.

Section 2 TEC FCNDK-FXA Helical Worm Gearbox

Performance (n1 with 4 pole 1400 rpm motor, SF = 1.0)

Size	40/63	50/63	63/63	50/71	63/71	75/71	90/71	63/80	75/80	90/80	110/80	110/100	130/100
n2 (rpm)	22.6	22.6	22.6	21.9	21.9	21.9	21.9	21.9	21.9	21.9	21.9	22.5	22.5
KW	0.25	0.42	0.74	0.42	0.74	0.95	1.60	0.74	0.95	1.60	3.20	3.20	4.94
Nm	76	131	234	135	242	315	537	242	315	537	1102	1073	1677
i1xi2	61.8	61.8	61.8	64.0	64.0	64.0	64.0	64.0	64.0	64.0	64.0	62.3	62.3
n2 (rpm)	18.0	18.0	18.0	17.5	17.5	17.5	17.5	16.9	16.9	16.9	16.9	16.7	16.7
KW	0.23	0.41	0.68	0.41	0.68	0.88	1.42	0.68	0.88	1.42	2.75	2.75	3.00
Nm	87	157	267	163	278	365	596	288	378	618	1212	1226	1338
i1xi2	77.7	77.7	77.7	80.0	77.7	77.7	77.7	83.0	83.0	83.0	83.0	84.0	84.0
n2 (rpm)	15.1	15.1	15.1	14.6	14.6	14.6	14.6	14.6	14.6	14.6	14.6	15.0	15.0
KW	0.17	0.30	0.52	0.30	0.52	0.68	1.10	0.52	0.68	1.10	2.40	2.40	3.72
Nm	72	127	230	131	238	316	518	238	316	518	1161	1146	1776
i1xi2	92.7	92.7	92.7	96.0	96.0	96.0	96.0	96.0	96.0	96.0	96.0	93.45	93.45
n2 (rpm)	12.0	12.0	12.0	11.7	11.7	11.7	11.7	11.2	11.2	11.2	11.2	11.1	11.1
KW	0.16	0.28	0.49	0.28	0.49	0.63	1.07	0.49	0.63	1.07	1.97	1.97	3.00
Nm	82	148	266	153	276	360	620	288	376	647	1226	1237	1884
i1xi2	116.60	116.55	116.55	120.0	120.0	120.0	120.0	124.5	124.5	124.5	124.5	126.0	126.0
n2 (rpm)	11.3	11.3	11.3	10.9	10.9	10.9	10.9	10.9	10.9	10.9	10.9	11.2	11.2
KW	0.12	0.20	0.40	0.20	0.40	0.50	0.84	0.40	0.50	0.84	1.80	1.80	2.71
Nm	61	106	226	110	235	298	508	235	298	508	1120	1090	1687
i1xi2	123.6	123.6	123.6	128.0	128.0	128.0	128.0	128.0	128.0	128.0	128.0	124.6	124.6
n2 (rpm)	9.0	9.0	9.0	8.8	8.8	8.8	8.8	8.4	8.4	8.4	8.4	8.3	8.3
KW	0.11	0.20	0.34	0.20	0.34	0.44	0.85	0.34	0.44	0.85	1.50	1.50	2.20
Nm	68	128	231	133	241	322	621	251	335	647	1210	1225	1797
i1xi2	155.4	155.4	155.4	160.0	160.0	160.0	160.0	166.0	166.0	166.0	166.0	168.0	168.0
n2 (rpm)	7.2	7.2	7.2	7.0	7.0	7.0	7.0	6.7	6.7	6.7	6.7	6.7	6.7
KW	0.10	0.18	0.32	0.18	0.32	0.49	0.67	0.32	0.49	0.67	1.35	1.35	1.80
Nm	75	134	201	142	262	421	576	278	440	602	1250	1257	1727
i1xi2	194.25	194.25	194.25	200.0	200.0	200.0	200.0	207.5	207.5	207.5	207.5	210.0	210.0
n2 (rpm)	6.0	6.0	6.0	5.8	5.8	5.8	5.8	5.6	5.6	5.6	5.6	5.6	5.6
KW	0.11	0.18	0.31	0.18	0.30	0.48	0.65	0.31	0.48	0.64	1.26	1.26	1.75
Nm	87	155	276	160	281	474	642	301	482	643	1289	1290	1780
i1xi2	233.1	233.1	233.1	240.0	240.0	240.0	240.0	249.0	249.0	249.0	249.0	252.0	252.0
n2 (rpm)	4.5	4.5	4.5	4.4	4.4	4.4	4.4	4.2	4.2	4.2	4.2	4.2	4.2
KW	0.08	0.13	0.21	0.13	0.21	0.28	0.48	0.21	0.28	0.48	0.97	0.97	1.20
Nm	74	130	227	132	232	322	562	243	337	589	1222	1230	1555
i1xi2	310.8	310.8	310.8	320.0	320.0	320.0	320.0	332.0	332.0	332.0	332.0	336.0	336.0
n2 (rpm)	3.6	3.6	3.6	3.5	3.5	3.5	3.5	3.4	3.4	3.4	3.4	3.3	3.3
KW	0.06	0.10	0.16	0.10	0.16	0.24	0.40	0.16	0.24	0.40	0.72	0.72	1.05
Nm	65	117	208	120	218	327	567	220	330	573	1045	1062	1670
i1xi2	388.5	388.5	388.5	400.0	400.0	400.0	400.0	415.0	415.0	415.0	415.0	420.0	420.0
n2 (rpm)	3.0	3.0	3.0	2.9	2.9	2.9	2.9	2.8	2.8	2.8	2.8	2.8	2.8
KW	0.05	0.08	0.13	0.09	0.13	0.18	0.32	0.14	0.18	0.31	0.62	0.62	0.80
Nm	60	102	170	118	176	255	506	196	264	508	1015	1015	1419
i1xi2	466.2	466.2	466.2	480.0	480.0	480.0	480.0	498.0	498.0	498.0	498.0	504.0	504.0

Nominal ratio in helical is 8:1 except for the shaded area which is 6:1. Other speeds are available. available. i1xi2 is the combined ratio of the helical and the worm gear.

Section 3 MBN Series Friction Mechanical Speed Variator

Summary

MBN Series Variators can be combined with other geared products in the TEC range to achieve slower variable speed reductions. Basic variator gives a stepless input speed variation ratio of 1:1.1-7. Housings are made from pressure die cast aluminium for sizes MBN2-MBN7 and cast iron for MB15-MB40.

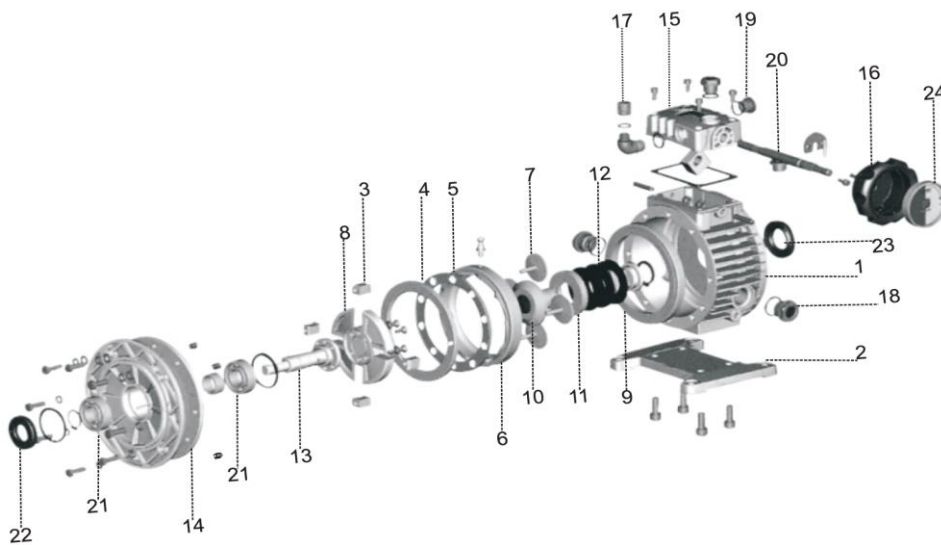

No.	Description
1	Housing
2	Foot plate
3	Slide-block bearing
4	Adjustable annulus ring
5	Ball ring
6	Fixed annulus ring
7	Planet disk
8	Planet carrier
9	Oil seal RCA
10	Fixed sun race
11	Adjustable sun race
12	Belleville spring
13	Output shaft
14	Output flange
15	Speed control cover
16	Speed control handle
17	Breather
18	Oil sight glass
19	Plug
20	Speed control lead screw
21	Bearing
22	Output oil seal
23	Input oil seal

Mounting positions

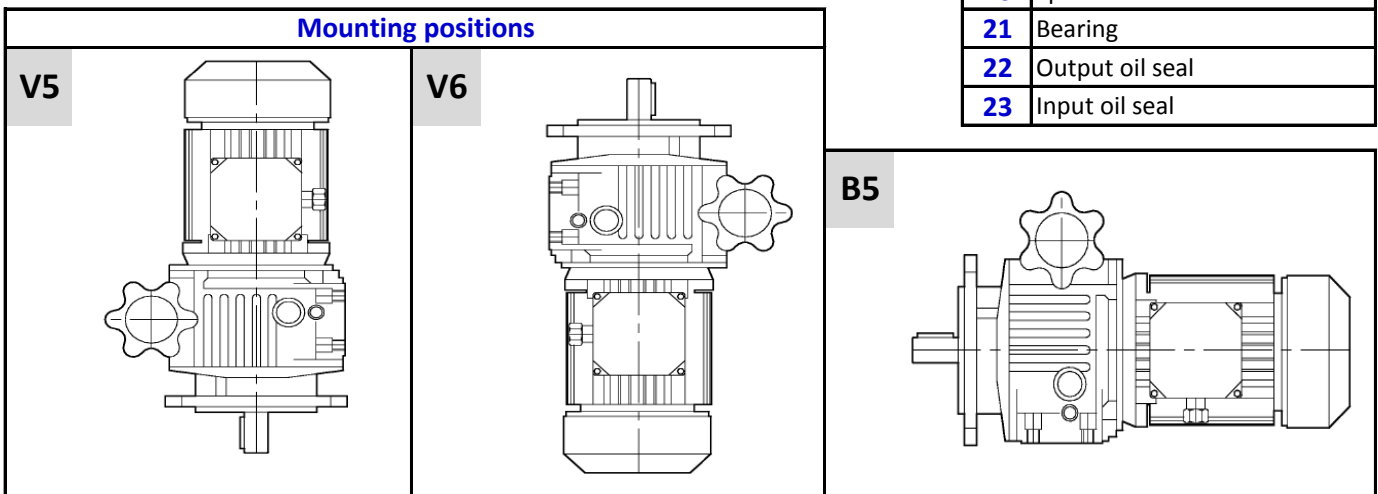

Unless specified all sizes are supplied lubricated with Automatic transmission fluid (A.T.F) for B5 mounting.
For mounting positions V5 & V6 a special extension breather is required.

Size	Oil fill quantity in litres		
	B5	V5	V6
MBN02	0.2	0.3	0.25
MBN04	0.3	0.5	0.45
MBN07	0.45	0.9	0.75
MB15	1.2	1.8	1.5
MB22	2.0	2.8	2.3
MB40	2.0	2.8	2.3

Installation - Dimensions

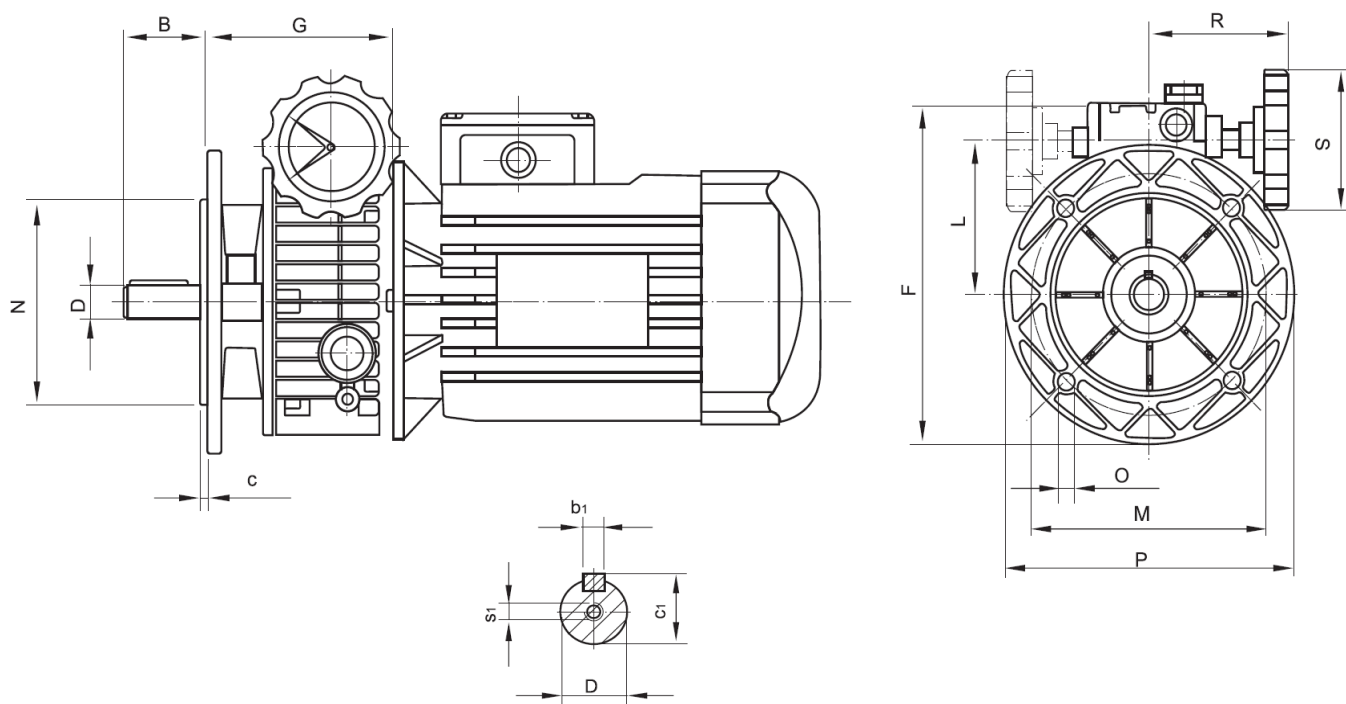

Variator ref	B	c	D	F	G	L	M	N	O	P	R	S	b1	c1	s1
MBN02	23	3.5	11	181	113	77	115	95	9	140	110	85	4	12.5	M6
MBN04	30	3.5	14	203	110	89	130	110	9	160	110	85	5	16	M6
MBN07	40	3.5	19	240	139	107	165	130	11	200	115	110	6	21.5	M6
MB15	50	4.0	24	286	173	121	165	130	15	200	135	110	8	27	M8
MB22	60	4.0	28	344	208	150	215	180	15	250	166	110	8	31	M8
MB40	60	4.0	28	344	208	150	215	180	15	250	166	110	8	31	M8

Performance (n1 with 4 pole 1400 rpm motor, sf = 1)

Variator ref	MBN02	MBN04	MBN07	MB15	MB22	MB40			
Kw	0.18	0.37	0.55	0.75	1.1	1.5	2.2	3	4
n2 (rpm)	880-175		1000-200						
M2 (Nm)	1.5-4	3.0-6	4.4-12	6.0-12	9.0-24	12.0-24	18-48	24-48	32-64

Recommended lubricants

AGIP	BP	CASTROL	ESSO	IP	MOBIL	SHELL
A.T.F. Dexron	Autran Dx	TQ Dexron II	A.T.F. Dexron	Dexron Fluid	A.T.F. 200 Red	Donax TG

Warning: Do not adjust the output speed when the variator is at standstill.

Weight (kg)

MBN02	MBN04	MBN07	MB15	MB22	MB40
2.3	3.3	6.1	21	51	51



**FRD - FOOT MOUNTED
HELICAL IN-LINE**



**FRS - FOOT MOUNTED RIGHT
ANGLE WORM**



**FRT - UNIVERSAL MOUNT
RIGHT ANGLE WORM**

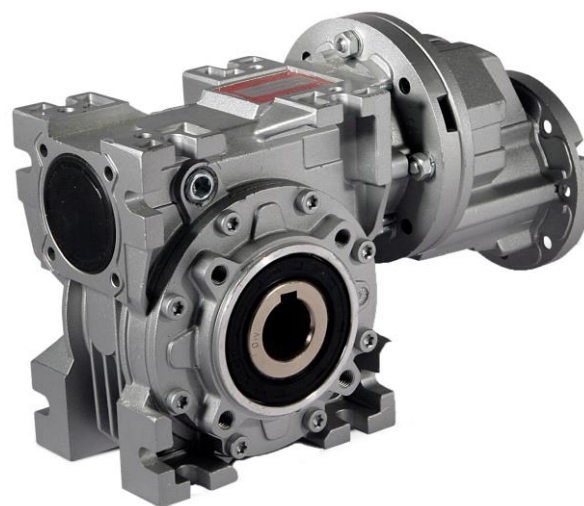

**FTA - UNIVERSAL MOUNT
HELICAL WORM**

Section 4 Varvel - Flexible Coupling "G"

The introduction of flexible coupling "G type" as replacement of traditional shaft/key fitting between motor and gearbox, gives various advantages but keeping unchanged gearbox overall dimensions. This facility is standard across the majority of the range of Varvel products.

Advantages

- One gearbox only, for each ratio
- Greater flexibility of motor mounting
- Increased stock rotation
- Fretting corrosion elimination
- Coupling zero backlash
- Angular misalignment 1 degree max.
- Torsional rigidity
- Vibration dampening

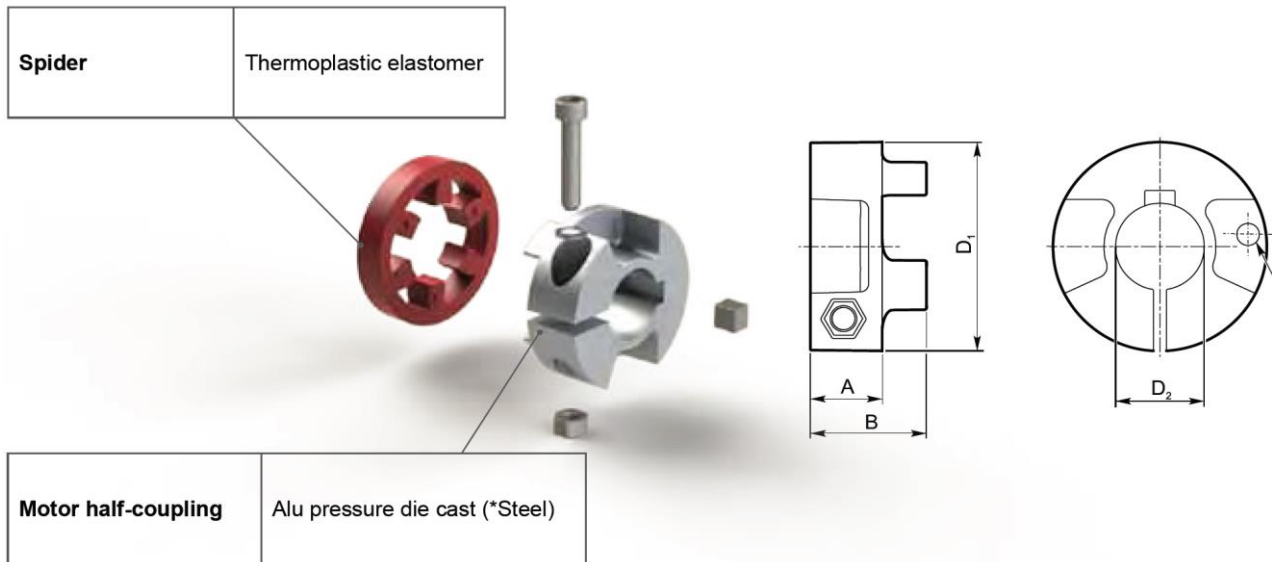

Coupling Ref	Kit code	RD Ref	RS-RT Ref	RO-RN Ref	A (mm)	B (mm)	D1 (mm)	D2 (mm)
G3	KG3.009	03	28-40				30	9
	KG3.011	03	28-40		11	19	30	11
	KG3.014	03	40				36	14
G5	KG5.009		50				45	9
	KG5.011	02-12-13-23	50-60	RN12-RN13-RO13	14.5	23	45	11
	KG5.014		50-60				45	14
	KG5.019	02-12-23	50-60				45	19
KG5.024	12-23	60	52				24	
G6	KG6.014		70					14
	KG6.019	22-32-33-42-43	70-85-110	RN22-43 RO23-43	19.5	31.5	58	19
	KG6.024		70-85-110					24
	KG6.028	22-32-42	70-85-110					28
G8*	KG8.019*							19
	KG8.024*	52-53-62-63						24
	KG8.028*			RN52-63 RO53-63	35	51	79	28
	KG8.038*	52-62-63						38
	KG8.042*	52-62						42
	KG8.048*	52-62						48

Summary

Two and three stage reductions. Modular design allows for both foot and flange mounting. Pressure die cast aluminium AISi12Cu2Fe sizes 0 to 4 and cast iron G25 for sizes 5 and 6. All sizes are supplied filled with synthetic long-life oil ISO VG 320.

- 7 Sizes
- Powers from 0.09 to 30 kW
- Ratios from 2.5:1 to 630:1
- Torques from 1 to 2300 Nm

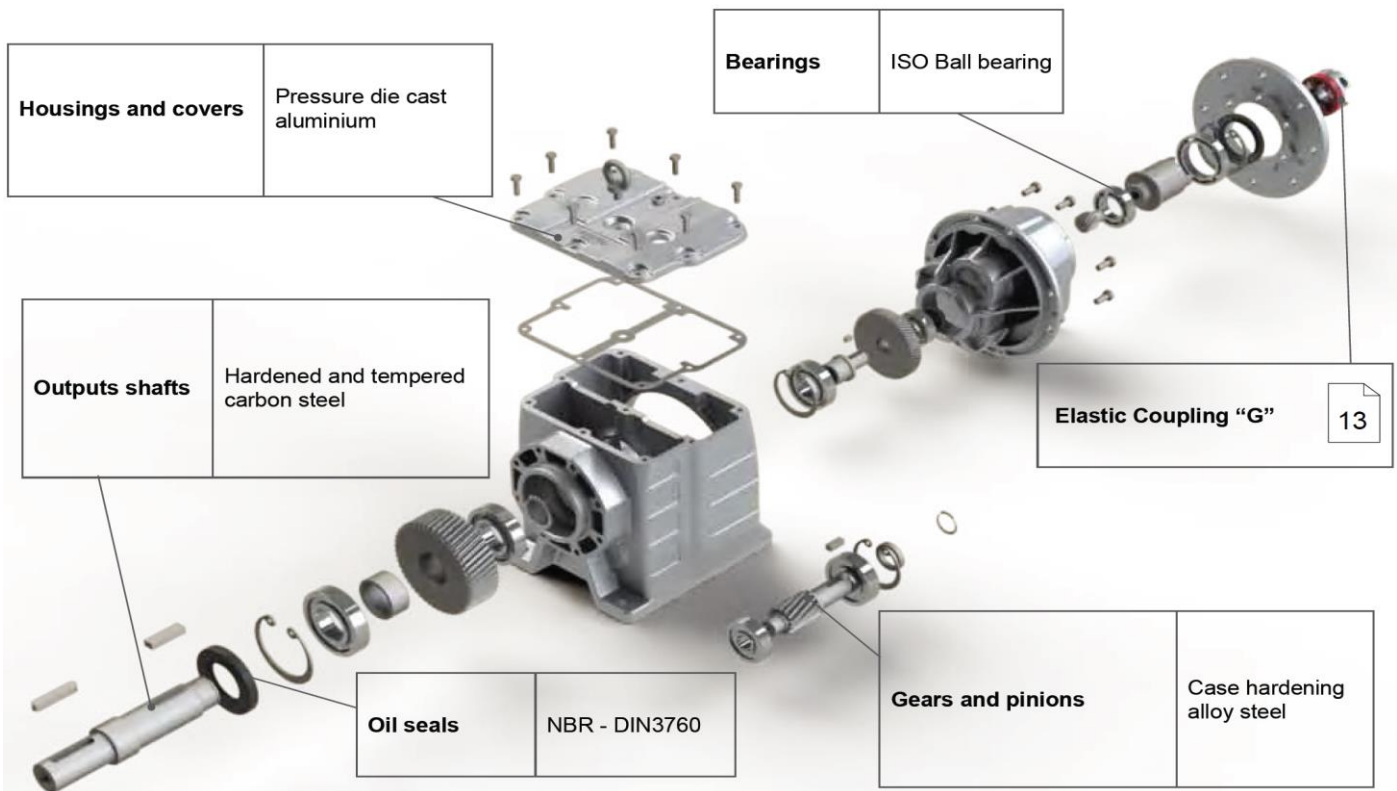

Oil fill quantity in litres														
Mounting	Size RD...													
	02	03	12	13	22	23	32	33	42	43	52	53	62	63
Horizontal	0.20	0.30	0.5	0.5	0.8	0.8	1.3	1.6	2.2	2.2	4.5	4.5	7.0	7.0
Vertical	0.28	0.38	0.7	0.7	1.0	1.0	1.8	2.1	3.0	3.4	5.5	6.5	9.0	11.0

Section 4 Varvel - RD Helical In-line

Performance (n1 with 4 pole 1400 rpm motor, SF = 1.0)

RD0				RD1				RD2				RD3			
Ratio	n2 (rpm)	P (KW)	M2 (Nm)	Ratio	n2 (rpm)	P (KW)	M2 (Nm)	Ratio	n2 (rpm)	P (KW)	M2 (Nm)	Ratio	n2 (rpm)	P (KW)	M2 (Nm)
2.568	545	1.82	30	2.534	560	2.50	45	2.546	560	4.99	85	2.697	560	10.49	190
3.277	427	1.57	33	3.081	445	2.21	45	3.133	445	4.37	90	3.324	445	9.18	205
4.256	329	1.32	36	4.011	350	1.84	50	3.917	350	3.75	100	4.160	350	7.87	220
5.276	265	1.13	38	5.073	280	1.55	55	5.013	280	3.12	105	5.331	280	6.55	235
6.253	234	1.22	48	6.686	220	2.06	90	6.717	220	4.13	175	6.261	220	9.31	370
7.979	175	0.97	49	8.129	175	1.71	90	8.267	175	3.39	180	7.717	175	7.63	370
10.362	135	0.78	50	10.581	140	1.33	90	10.333	140	2.74	180	9.658	140	6.17	375
12.844	109	0.62	50	13.384	110	1.06	90	13.227	110	2.17	180	12.375	110	4.87	380
16.320	86	0.49	51	16.304	90	0.88	90	16.290	90	1.78	185	16.451	90	3.72	390
21.533	65	0.38	51	20.391	70	0.71	90	20.667	70	1.42	190	19.362	70	3.19	390
26.747	52	0.31	52	26.522	55	0.56	95	26.729	55	1.11	190	25.255	55	2.48	395
30.222	46	0.27	52	32.653	45	0.46	95	31.477	45	0.95	190	33.214	45	1.68	400
34.675	40	0.16	35	39.083	35	0.27	70	39.388	35	0.53	140	38.214	35	1.10	285
43.070	33	0.13	35	48.118	30	0.22	70	50.758	30	0.41	140	50.727	30	0.85	285
48.667	29	0.11	35	61.670	22	0.17	70	62.127	22	0.34	140	63.333	22	0.69	285
36.892	37	0.22	52	40.103	35	0.38	95	40.759	35	0.75	200	38.063	35	1.68	420
47.074	30	0.18	52	52.201	30	0.29	95	52.172	30	0.59	200	48.772	30	1.33	420
61.135	23	0.14	52	66.028	22	0.23	95	64.256	22	0.48	200	64.836	22	1.01	420
75.782	18	0.11	52	80.432	18	0.19	100	81.519	18	0.39	200	76.310	18	0.87	420
96.288	15	0.09	52	100.596	14	0.16	100	105.431	14	0.30	200	99.535	14	0.67	425
127.047	11	0.07	52	130.843	11	0.12	100	124.159	11	0.25	200	130.903	11	0.51	425
157.805	8.9	0.05	52	165.075	9.0	0.10	100	164.938	9.0	0.19	200	167.799	9.0	0.40	425
178.311	7.9	0.05	52	206.460	7.0	0.08	100	209.250	7.0	0.15	200	197.495	7.0	0.34	425
204.583	6.9	0.03	36	268.538	5.5	0.06	100	270.630	5.5	0.12	200	257.602	5.5	0.26	430
254.113	5.5	0.02	36	330.615	4.5	0.05	100	318.704	4.5	0.10	200	307.214	4.5	0.22	430
287.133	4.9	0.02	36	395.719	3.5	0.03	70	398.802	3.5	0.06	140	393.429	3.5	0.11	290
324.444	4.3	0.02	36	487.197	2.8	0.02	70	513.920	2.8	0.04	140	517.418	2.8	0.09	290
				624.413	2.2	0.02	70	629.039	2.2	0.04	140	646.000	2.2	0.07	290

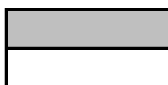

Two reduction stages
Three reduction stages

Section 4 Varvel - RD Helical In-line

Performance (n1 with 4 pole 1400 rpm motor, SF = 1.0)

RD4				RD5				RD6			
Ratio	n2 (rpm)	P (KW)	M2 (Nm)	Ratio	n2 (rpm)	P (KW)	M2 (Nm)	Ratio	n2 (rpm)	P (KW)	M2 (Nm)
2.489	560	17.70	300	2.556	548	34.00	630	2.616	535	70.00	1300
3.111	445	15.30	320	3.241	432	30.00	690	3.318	422	60.00	1400
3.960	350	14.20	380	3.926	357	29.00	750	4.019	348	58.00	1600
4.830	280	12.30	400	4.840	289	26.80	850	4.955	283	55.40	1800
6.286	220	15.20	620	6.454	217	27.40	1160	6.571	213	46.80	2000
7.857	175	12.30	620	8.185	171	21.80	1170	8.333	168	36.60	2000
10.000	140	9.80	620	9.915	141	18.10	1180	10.095	139	31.70	2100
12.199	110	8.00	620	12.222	115	14.80	1190	12.444	113	25.70	2100
15.223	90	6.60	650	15.452	91	11.80	1200	15.733	89	20.30	2100
19.643	70	5.70	650	20.298	69	9.10	1220	20.667	68	15.50	2100
24.478	55	4.20	650	25.989	54	7.20	1230	24.615	57	13.00	2100
29.643	45	3.50	650	31.429	45	6.00	1240	33.200	42	10.00	2220
41.538	35	1.50	450	40.476	35	3.20	850	40.500	35	6.00	1600
50.303	30	1.20	450	53.333	26	2.40	850	49.800	28	4.90	1600
62.963	22	1.10	450	66.667	21	1.90	850	56.000	25	4.30	1600
41.875	35	2.50	700	39.333	36	5.00	1270	39.708	35	8.60	2200
51.084	30	2.10	700	47.984	29	4.10	1280	48.948	29	7.00	2200
63.747	22	1.70	700	59.878	23	3.40	1290	61.884	23	5.50	2200
82.254	18	1.40	700	77.262	18	2.60	1300	81.289	17	4.40	2300
102.129	14	1.10	700	96.280	15	2.10	1300	104.082	13	3.70	2300
124.129	11	0.90	700	129.800	11	1.60	1300	125.867	11	3.40	2300
160.689	9.0	0.70	700	157.143	8.9	1.30	1300	157.333	9.0	2.80	2300
207.341	7.0	0.60	700	195.824	7.1	1.10	1300	201.571	6.9	1.80	2300
258.379	5.5	0.40	700	264.000	5.3	0.80	1300	265.600	5.3	1.40	2300
312.897	4.5	0.35	700	332.308	4.2	0.45	900	332.000	4.2	1.10	2300
438.462	3.5	0.22	460	402.424	3.5	0.35	900	373.333	3.8	1.60	2300
530.976	2.8	0.12	460	503.704	2.8	0.30	900	448.000	3.1	0.80	2300
664.609	2.2	0.11	460	629.630	2.2	0.25	900	560.000	2.5	0.70	2300



Two reduction stages
Three reduction stages

Installation - Dimensions

B3

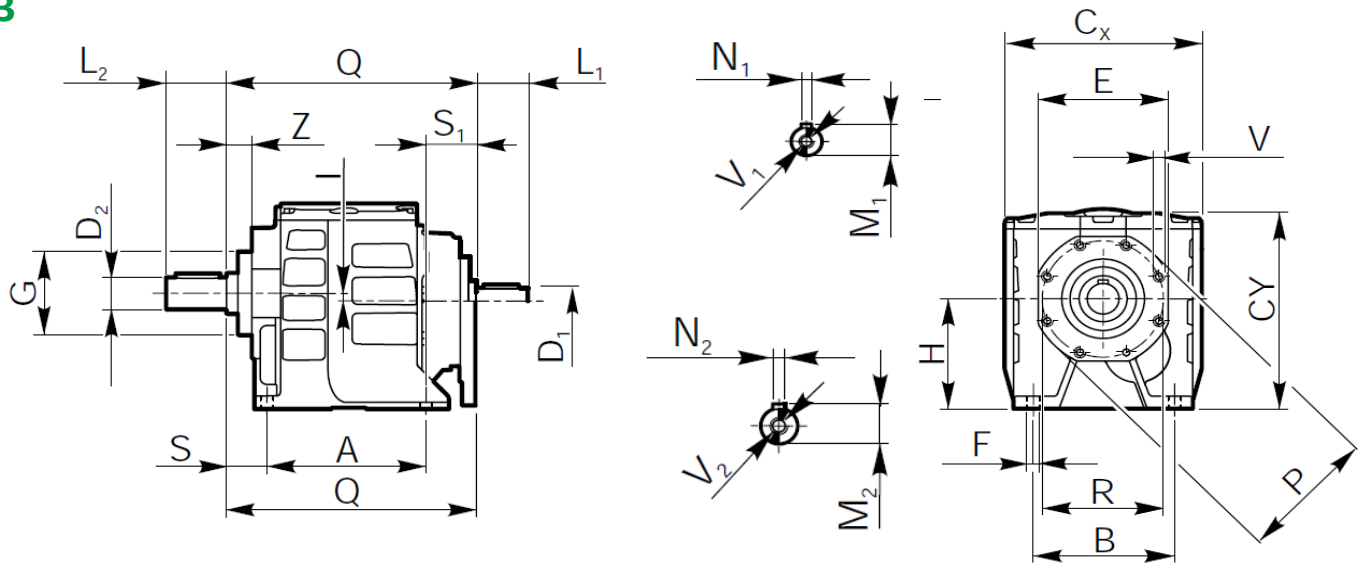

	RD02	RD03	RD12	RD13	RD22	RD23	RD32	RD33
A	95		110		130		165	
B	80		110		110		135	
C_x	100		140		155		190	
C_y	111		131		158		198	
D₁ h6	11		14		19		24	
D₂ h6	17 - 20		20 - 25		25 - 30		30 - 35	
E	82		82		102		125	
E₁	100 (115) [130]		100 (115) [130]		115 (130) [165]		130 (165) [215]	
F	9		9		9		11.5	
F₁	7 (9) [9]		7 (9) [9]		9 (9) [11]		9 (11) [13]	
G g6	60		60		65		85	
G₁ h7	80 (95) [110]		80 (95) [110]		95 (110) [130]		110 (130) [180]	
H	60		75		90		115	
I	4.5		5		6		8.5	
L₁	23		30		40		50	
L₂	35 (40)		40 (50)		50 (60)		60 (70)	
M₁	12.5		16		21.5		27	
M₂	19 - 22.5		22.5 - 28		28 - 33		33 - 38	
N₁	4		5		6		8	
N₂	5 - 6		6 - 8		8 - 8		8 - 10	
P	84		84		108		130	
P₁	120 (140) [160]		120 (140) [160]		140 (160) [200]		160 (200) [250]	
Q	140	143	151	161	190	208	220	253
R	75		75		95		115	
R₁	100 (115) [130]		100 (115) [130]		115 (130) [165]		130 (165) [215]	
S	20		18		25		30	
S₁	25	28	23	33	35	53	25	58
U₁	3 (3) [3]		3 (3) [3]		3 (3) [3]		3.5 (3.5) [3.5]	
V	M6x14 (n° 7)		M6x14 (n° 7)		M6x10 (n° 8)		M8x18 (n° 8)	
V₁	M5x12		M5x12		M6x16		M8x19	
V₂	M6x16 - M6x16		M6x16 - M6x16		M6x16 - M10x22		M10x22 - M10x22	
Z	13		10		13		13	
kg	3.0	3.2	4.8	4.8	7.9	8.5	13.5	14.5



Two reduction stages
Three reduction stages

Installation - Dimensions

B5

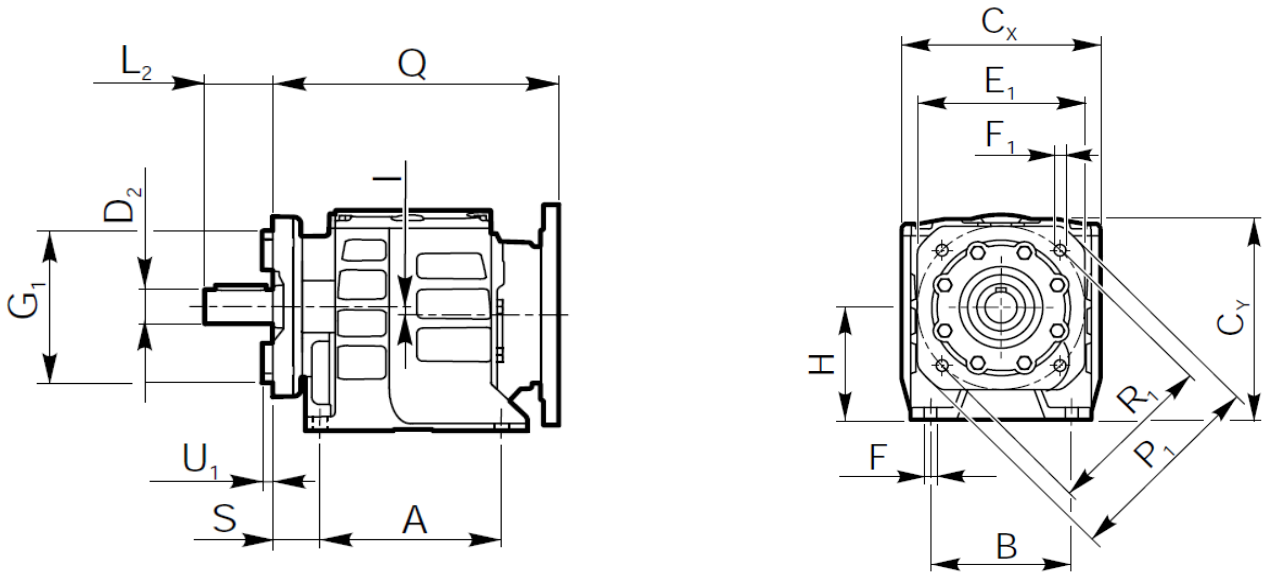

	RD42	RD43	RD52	RD53	RD62	RD63
A	195		205		260	
B	150		170		215	
C _x	215		284		340	
C _y	222		255		302	
D ₁ h6	28		38		48	
D ₂ h6	35 - 40		40 - 50		50 - 60	
E	142		180		180	
E ₁	165 (215) [265]		215 (265) [300]		215 (265) [300]	
F	13.5		18		18	
F ₁	11 (13.5) [17]		13.5 (17.5) [17.5]		13.5 (17.5) [17.5]	
G g6	95		130		130	
G ₁ h7	130 (180) [230]		180 (230) [250]		180 (230) [250]	
H	130		140		180	
I	13.5		0		0	
L ₁	60		80		100	
L ₂	70 (80)		80 (100)		100 (120)	
M ₁	31		41		51.5	
M ₂	38 - 43		43 - 53.5		53.5 - 64	
N ₁	8		10		14	
N ₂	10 - 12		12 - 14		14 - 18	
P	145		190		190	
P ₁	200 (250) [300]		250 (300) [350]		250 (300) [350]	
Q	265	305	353 [367]		410 [424]	
R	130		165		165	
R ₁	165 (215) [265]		215 (265) [300]		215 (265) [300]	
S	30		35 [49]		40 (54)	
S ₁	40	80	82		79	
U ₁	4 (4) [4]		4 (4) [4]		4 (4) [4]	
V	M8x18 (n° 8)		M10x25 (n° 8)		M10x25 (n° 8)	
V ₁	M10x22		M12x28		M16x36	
V ₂	M10x22 - M12x28		M12x28 - M16x36		M16x36 - M20x42	
Z	15		18		18	
kg	20	21.5	49	52	62	70



Two reduction stages
Three reduction stages

Summary

Varvel RT and RS worm gear box cases are made from pressure die cast aluminium AISi12Cu2Fe for sizes 28 to 85 and cast iron for sizes 110 to 150. All sizes are supplied filled with synthetic long-life oil ISO VG 320.

- 9 Sizes
- Powers from 0.09 to 15 kW
- Ratios from 5:1 to 100:1 (single reduction)
- Torques from 2 to 1576 Nm

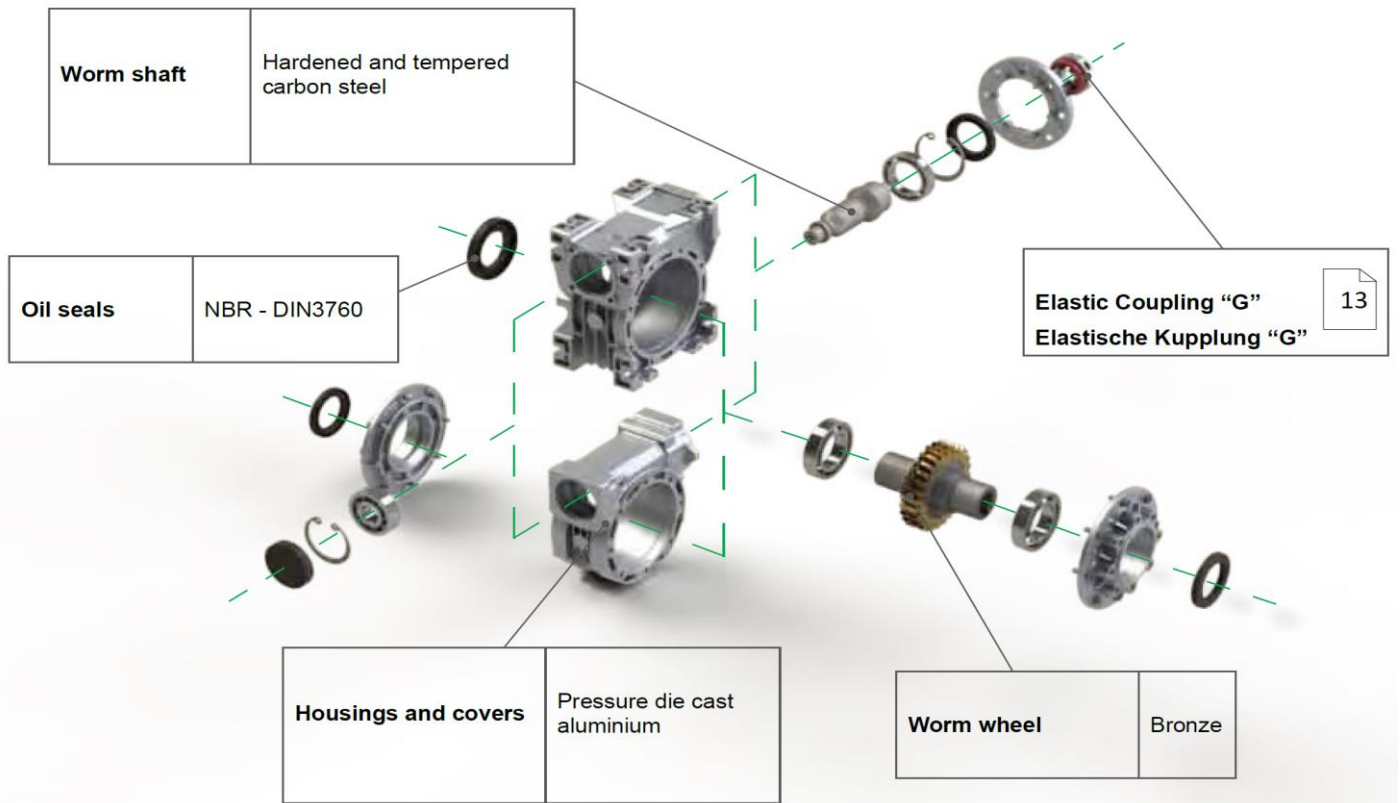

Section 4 Varvel - RS/RT Worm Gearbox

Performance (n1 with 4 pole 1400 rpm motor, SF = 1.0)

RS RT	Ratio n2 (rpm)	5 280	7 200	10 140	15 93	20 70	28 50	40 35	49 29	56 25	70 20	80 18	100 14
RS - RT 28	kW		0.45	0.33	0.23	0.16	0.16	0.10	0.09	0.08	0.06	0.05	0.03
	Nm		18	18	18	16	20	17	17	15	12	12	8
	eff.		0.84	0.81	0.77	0.74	0.66	0.62	0.57	0.51	0.45	0.45	0.43
RS - RT 40	kW	1.5	1.1	0.81	0.55	0.38	0.37	0.25	0.21	0.18	0.14	0.12	0.09
	Nm	45	45	46	44	39	48	42	41	38	36	32	29
	eff.	0.87	0.85	0.83	0.78	0.75	0.68	0.61	0.58	0.56	0.52	0.50	0.46
RS - RT 50	kW	2.7	1.8	1.3	0.93	0.63	0.63	0.41	0.37	0.31	0.25	0.20	0.13
	Nm	81	75	75	74	65	85	72	76	71	63	58	43
	eff.	0.88	0.86	0.84	0.78	0.76	0.71	0.64	0.62	0.60	0.53	0.52	0.47
RS - RT 60	kW	4.1	2.8	2.3	1.6	1.2	1.0	0.75	0.62	0.54	0.46	0.37	0.25
	Nm	125	113	133	130	122	139	135	128	123	122	106	83
	eff.	0.89	0.86	0.84	0.81	0.77	0.71	0.66	0.62	0.60	0.55	0.53	0.49
RS - RT 70	kW	5.7	4.0	3.1	2.2	1.8	1.5	1.2	0.84	0.74	0.58	0.50	0.37
	Nm	176	166	180	188	194	216	238	189	180	163	154	130
	eff.	0.89	0.88	0.86	0.83	0.81	0.75	0.71	0.67	0.64	0.59	0.56	0.52
RS - RT 85	kW	9.1	6.2	4.6	3.4	2.9	2.2	1.6	1.4	1.2	0.96	0.86	0.55
	Nm	279	259	268	289	322	319	325	316	305	290	280	210
	eff.	0.90	0.88	0.86	0.83	0.82	0.76	0.72	0.67	0.68	0.63	0.60	0.56
RS - RT 110	kW		12.5	9.0	6.5	5.7	4.4	3.5	2.7	2.2	2.0	1.5	1.1
	Nm		525	532	560	647	642	691	631	595	635	525	469
	eff.		0.88	0.87	0.84	0.83	0.76	0.73	0.71	0.70	0.67	0.66	0.61
RS 130	kW		19.0	15.0	11.0	8.5	7.5	5.5	3.9	3.7	2.7	2.4	1.8
	Nm		807	890	960	975	1100	1140	950	1005	865	810	750
	eff.		0.89	0.87	0.85	0.84	0.77	0.76	0.72	0.71	0.67	0.63	0.61
RS 150	kW		24.9	21.0	16.0	12.5	9.5	8.0	5.9	5.1	3.8	3.3	2.6
	Nm		1060	1260	1410	1430	1435	1680	1440	1420	1230	1170	1120
	eff.		0.89	0.88	0.86	0.84	0.79	0.77	0.73	0.73	0.68	0.65	0.63

Installation - Dimensions

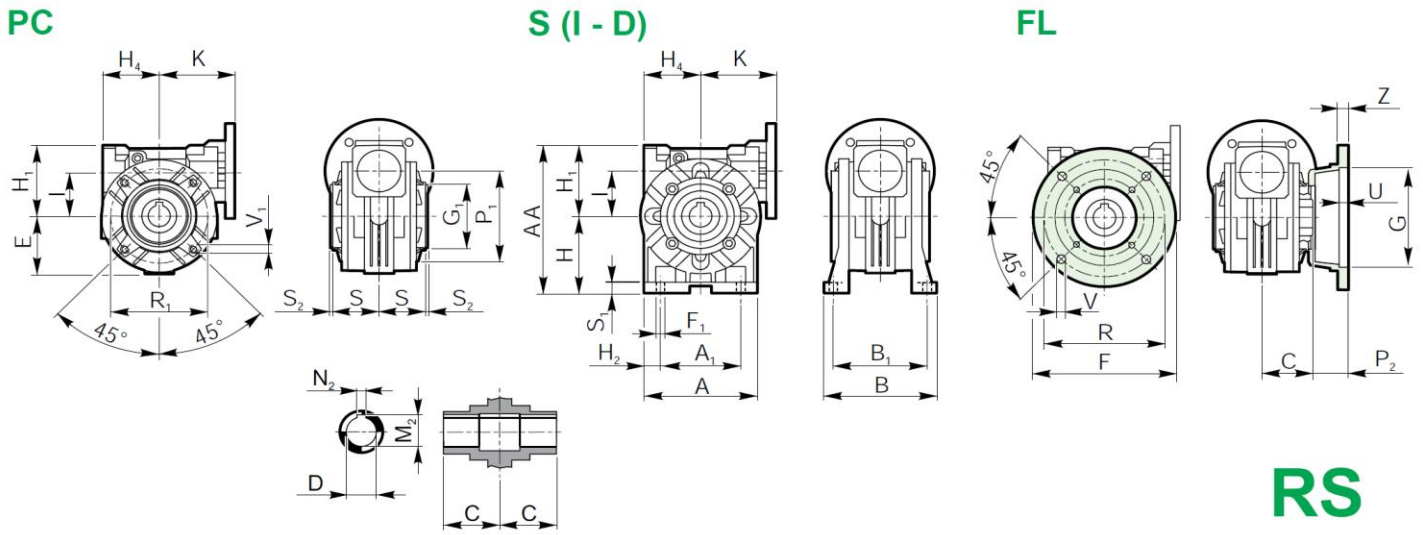

	RS28	RS40	RS50	RS60	RS70	RS85	RS110	RS130	RS150
A	70	100	120	138	158	193	250	286	336
A ₁	52	70	85	95	120	140	200	235	260
AA	99	138	163	192	221	252	333	400	454
B	78	102	119	136	140	168	200	230	250
B	66	84	99	111	116	140	162	190	210
C	30	41	49	60	60	61	77.5	90	105
DH7	14	19 - 18	24 - 25	25	28 - 30	32 - 35	42	48	55
E	34	50	61	70	80	98	125	143	168
F	70	140	160	180	200	200	250	300	350
F ₁	5.5	7	9	11	11	13	14	15	19
G H8	40	95	110	115	130	130	180	230	250
G ₁ H8	42	60	70	70	80	110	130	180	180
H	52	71	85	100	115	135	172	200	230
H ₁	47	67	78	92	106	117	161	200	224
H ₂	9	15	17.5	21.5	19	26.5	25	25.5	38
H ₄	40	50	60	72	86	103	139	159	183
I	28	40	50	60	70	85	110	130	150
K	57.5	70.5	83 - 88*	93 - 94*	117 - 118*	134 - 137*	151 - 153*	165 - 166*	191 - 211*
M ₂	16.3	21.8 - 20.8	27.3 - 28.3	28.3	31.3 - 33.3	35.3 - 38.3	45.3	51.8	59.3
N ₂	5	6 - 6	8 - 8	8	8 - 8	10 - 10	12	14	16
P	49	82	91.5	116	111	100	150	150	160
P ₁	67	94	100	102	118	150	200	234	250
P ₂	19	41	42.5	56	51	39	72.5	60	55
R	56	115	130	150	165	165	215	265	300
R ₁	56	83	85	85	100	130	165	215	215
S	32	38	49	57.5	57	56.5	74.5	87	102
S ₁	6	9	12	12	14	15	17	19	20
S ₂	- 3	2	2.5	2.5	3	3	2.5	5	5
U	4	6	10	10	12	6	5	5	6
V	6.5 (n°4)	9 (n°4)	9 (n°4)	11 (n°4)	13 (n°4)	13 (n°4)	15 (n°8)	15 (n°8)	19 (n°8)
V ₁	M6x6 (n°4)	M6x9 (n°4)	M8x12 (n°4)	M8x15 (n°8)	M8x18 (n°8)	M10x20 (n°8)	M12x21 (n°8)	M12x24 (n°8)	M14x30 (n°8)
Z	6	10	10	11	14	14	16	18	20
Kg	1.1	2.5	3.8	6.5	9	13.5	39	50	80

* - IEC71-B14 (RS50 - RS60) - IEC80-B14 (RS70) - IEC90-B14 (RS85) - IEC100/112-B14 (RS110 - RS130 - RS150)

Installation - Dimensions

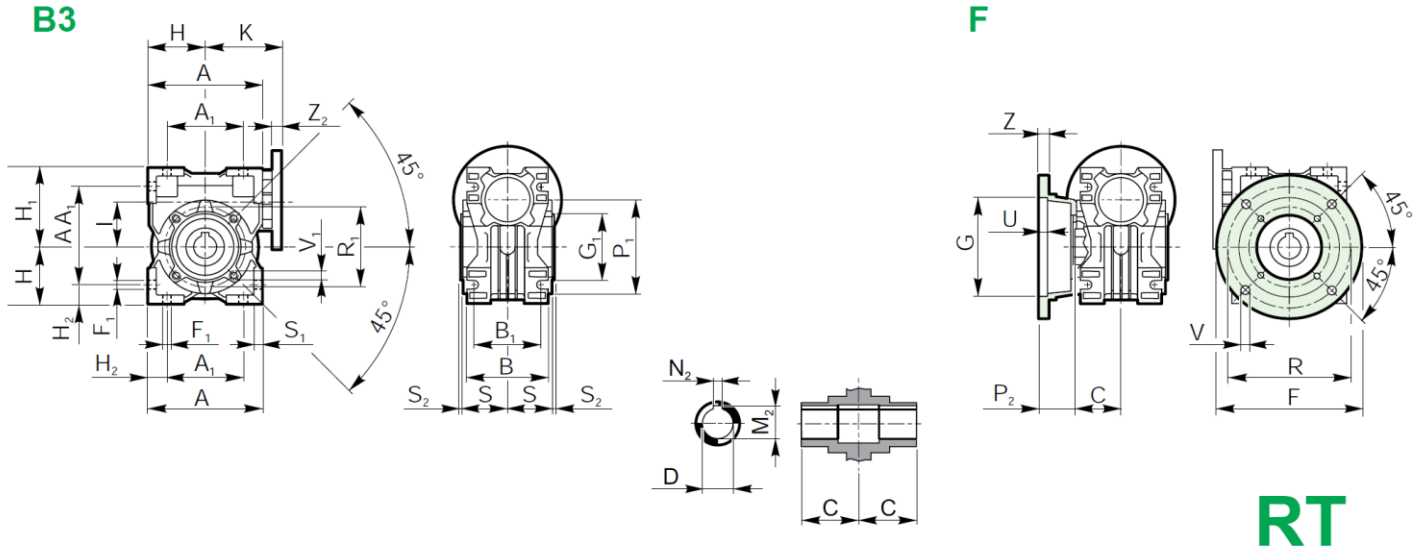

	RT28	RT40	RT50	RT60	RT70	RT85	RT110
A	80	100	120	144	172	206	255
A ₁	54	70	80	100	120	140	170
AA	97	121.5	144	174	205	238	295
AA ₁	71	91.5	104	130	153	172	210
B	53	71	85	100	112	130	144
B ₁	44	60	70	85	90	100	115
C	30	41	49	60	60	61	77.5
D H7	14	19 - 18	24 - 25	25	28 - 30	32 - 35	42
F	80	110	125	180	200	210	270
F ₁	7	7	9	9	11	13	15
G H8	50	60	70	115	130	152	170
G ₁ H8	55	60	70	80	95	110	130
H	40	50	60	72	86	103	127.5
H ₁	57	71.5	84	102	119	135	167.5
H ₂	13	15	20	22	26	33	42.5
I	28	40	50	60	70	85	110
K	57.5	70.5	83 - 88*	93 - 94*	117 - 118*	134 - 137*	151 - 153*
M ₂	16.3	21.8 - 20.8	27.3 - 28.3	28.3	31.3 - 33.3	35.3 - 38.3	45.3
N ₂	5	6 - 6	8 - 8	8	8 - 8	10 - 10	12
P	53	69	93	86	111	111	131
P ₁	75	86	100	110	130	160	200
P ₂	23	28	44	25	51	50	53.5
R	68	87	90	150.5	165	175	230
R ₁	65	75	85	95	115	130	165
S	27.5	38.5	46.5	57	57	67	74
S ₁	6	7	8	10	11	14	13
S ₂	2.5	2.5	3	3	3	3	3.5
U	10	4	5	6.5	12	6	5
V	7 (n° 4)	9 (n° 4)	11 (n° 4)	11 (n° 4)	13 (n° 4)	13 (n° 4)	14 (n° 8)
V ₁	M6x10 (n° 4)	M6x8.5 (n° 4)	M8x10 (n° 4)	M8x20 (n° 8)	M8x16 (n° 8)	M10x18 (n° 8)	M10x21 (n° 8)
Z	7	6	10	10	14	16	18
Z ₂	13	13	13	14 - 15	15.5 - 17.5	15.5 - 18.5	18 - 20
KG	1.1	2.5	3.8	6.5	9	13.5	39

* - IEC71-B14 (RT50 - RT60) - IEC80-B14 (RT7) - IEC90-B14 (RT85) - IEC100/112-B14 (RT110)

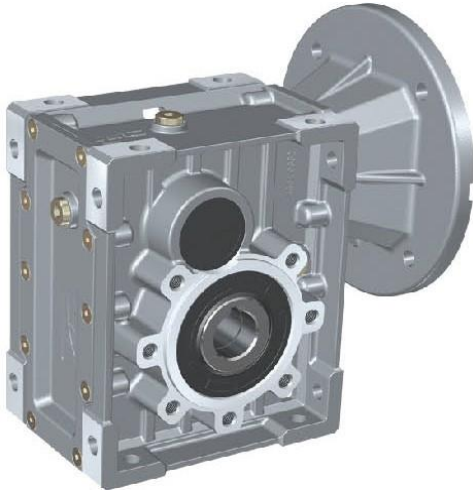

TKM...B 2 STAGE BEVEL HELICAL GEAR UNIT MOTOR READY

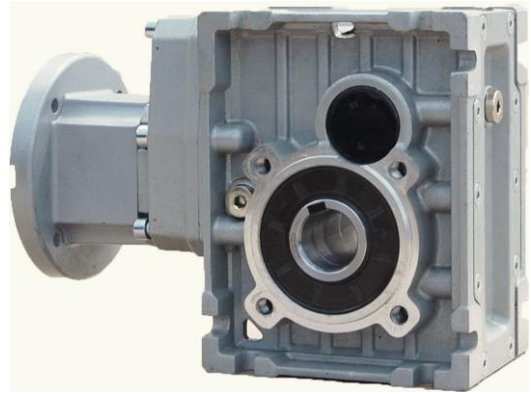

TKM...C 3 STAGE BEVEL HELICAL GEAR UNIT MOTOR READY

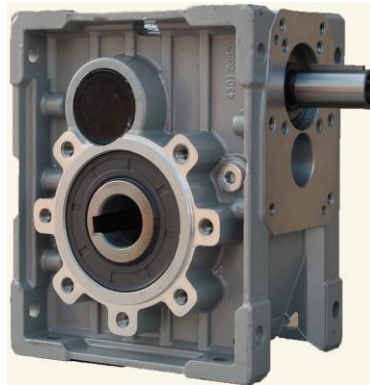

TKM...B-HS BEVEL HELICAL REDUCER



TKM...B BEVEL HELICAL GEARED MOTOR

Section 5 TEC TKM Bevel Helical Gearbox

Summary

TKM series bevel helical gear units have been designed based on the modular format system. All types of IEC motors can be fitted. The versatility of the design lends itself to all types of mounting. All sizes in this range are supplied filled with synthetic long-life oil grade ISO VG 320. Housings are made from die-cast aluminium. Gears made from 20CrMnTiH1 hardened steel. Colour RAL9022

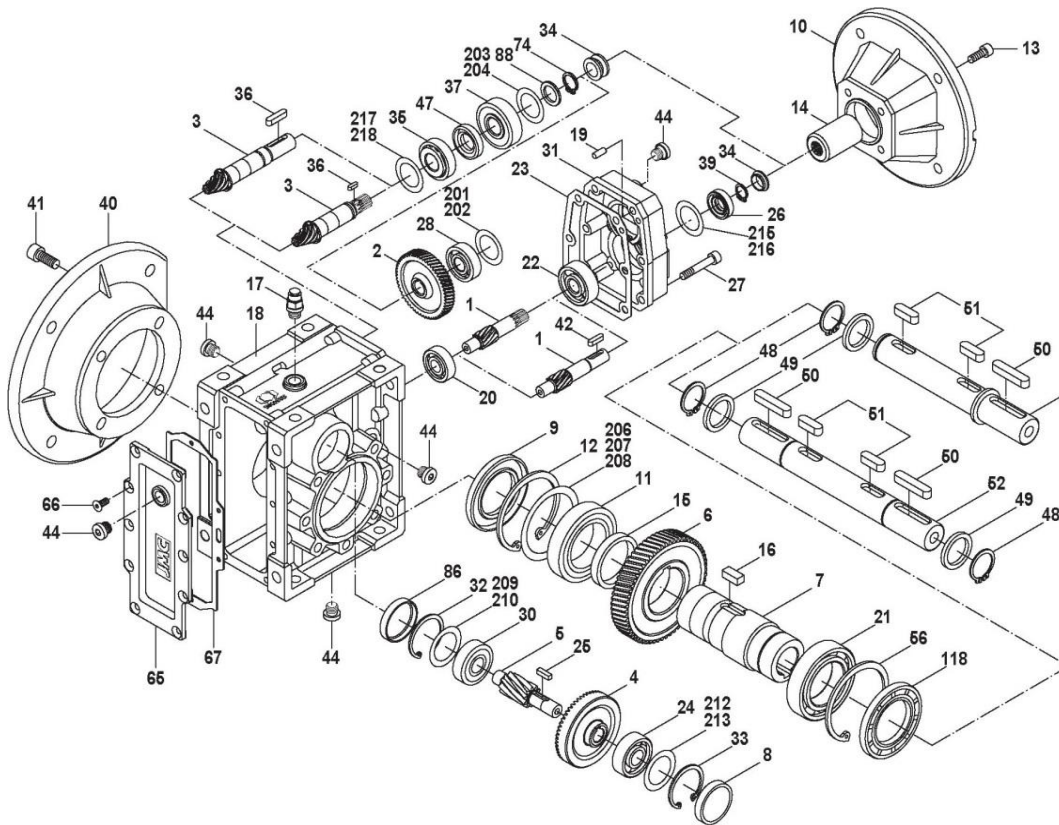

No.	Main Parts
1	Helical pinion (3 stg)
2	Helical gear (3 stg)
3	Bevel pinion
4	Bevel gear
5	Output pinion
6	Helical gear
7	Output hub
8	Oil seal RCA
9	Oil seal
10	Input flange
11	Bearing
14	Input coupling
18	Housing
20	Bearing
22	Bearing
31	3 stage gear-case
35	Bearing
37	Input bearing
40	Output flange
56	Circlip

Mounting positions

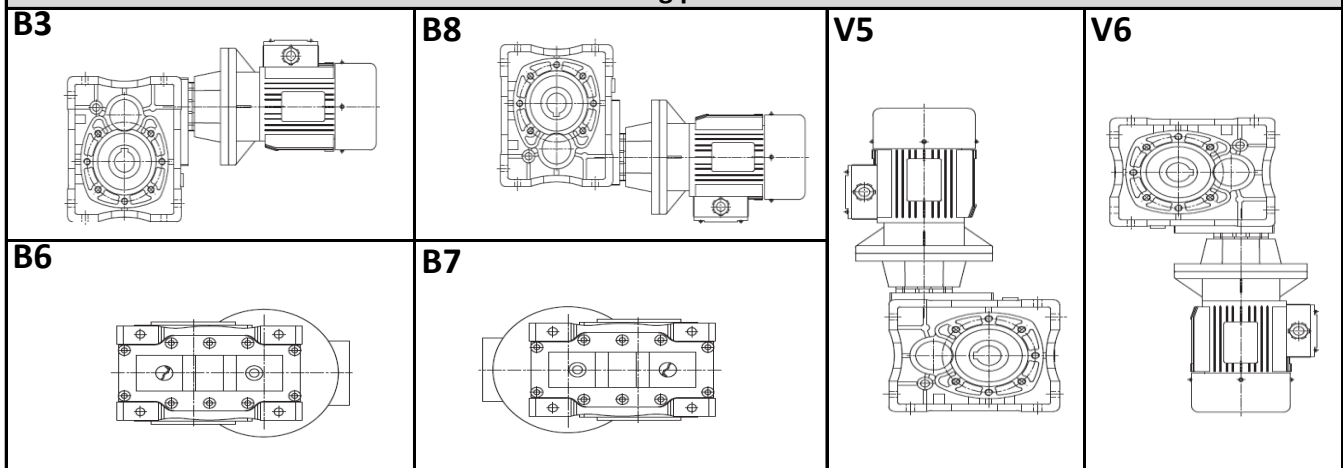

Oil fill quantity in litres

Mtg	TKM28B	TKM28C	TKM38B	TKM38C	TKM48B	TKM48C	TKM58B	TKM58C
B3							1.21	
B6							0.95	
B7							0.72	
B8	0.20	0.06	0.35	0.06	0.60	0.13	0.67	0.13
V5							1.30	
V6							0.74	

The specified quantities are a recommended value, however amount can vary slightly by ratio due to the size of the gears. Apart from size TKM58, all units are filled with long life synthetic lubricant for universal mounting.

Section 5 TEC TKM Bevel Helical Gearbox

TKM28.. Performance (n ₁ with 4 pole 1400 rpm motor, sf = 1)							130Nm			
Ref	Ratio	n ₂ (rpm)	kW	M ₂ (Nm)	F _{r2} (N)	63B5	71B5 71B14	80B5 80B14	90B5 90B14	
2 Stage										
TKM28B	7.73	182	2.02	100	1510					
	10.47	134	1.94	130	1670					
	12.47	113	1.64	130	1770					
	14.92	94	1.36	130	1880					
	20.21	70	1.01	130	2080					
	24.07	59	0.85	130	2200					
	29.33	48	0.70	130	2350					
	40.09	35	0.51	130	2610					
	48.86	29	0.42	130	2790					
	58.36	24	0.29	110	2960					
3 Stage										
TKM28C	52.36	27	0.34	110	2860					
	62.36	23	0.31	120	3030					
	74.62	19	0.28	130	3220					
	101.04	14	0.21	130	3560					
	120.34	12	0.18	130	3770					
	146.67	9.6	0.14	130	4000					
	200.44	7.0	0.10	130	4100					
	244.29	5.8	0.09	130	4100					
	291.79	4.8	0.06	110	4100					

TKM38.. Performance (n ₁ with 4 pole 1400 rpm motor, sf = 1)							200Nm			
Ref	Ratio	n ₂ (rpm)	kW	M ₂ (Nm)	F _{r2} (N)	63B5	71B5 71B14	80B5 80B14	90B5 90B14	
2 Stage										
TKM38B	7.60	185	2.06	100	1710					
	10.50	134	2.02	135	1910					
	12.67	111	2.04	165	2030					
	14.67	96	2.03	190	2130					
	20.25	70	1.56	200	2380					
	24.44	58	1.29	200	2530					
	30.31	47	1.05	200	2720					
	39.29	36	0.80	200	2970					
	48.71	29	0.65	200	3190					
	60.50	24	0.45	170	3430					
3 Stage										
TKM38C	52.48	27	0.37	120	3270					
	63.33	23	0.37	140	3480					
	73.33	20	0.36	160	3650					
	101.27	14	0.32	200	4070					
	122.22	12	0.27	200	4330					
	151.56	9.3	0.21	200	4650					
	196.43	7.2	0.16	200	4800					
	243.57	5.8	0.13	200	4800					
	302.5	4.7	0.09	170	4800					

Section 5 TEC TKM Bevel Helical Gearbox

TKM48.. Performance (n ₁ with 4 pole 1400 rpm motor, sf = 1)						350Nm			
Ref	Ratio	n ₂ (rpm)	kW	M ₂ (Nm)	Fr ₂ (N)	71B5	80B5 80B14	90B5 90B14	100-112B5 & B14
2 Stage									
TKM48B	7.48	188	5.86	280	2330				
	9.84	143	5.58	350	2550				
	12.49	113	4.41	350	2770				
	15.09	93	3.63	350	2950				
	19.84	71	2.77	350	3230				
	25.19	56	2.18	350	3500				
	30.24	47	1.83	350	3720				
	40.13	35	1.36	350	4080				
	48.18	30	1.17	350	4340				
59.44	24	0.94	350	4660					
3 Stage									
TKM48C	49.18	29	1.16	350	4370				
	62.43	23	0.92	350	4730				
	75.45	19	0.76	350	5040				
	99.22	15	0.60	350	5520				
	125.95	12	0.48	350	5980				
	151.20	9.3	0.37	350	6500				
	200.66	7.0	0.28	350	6500				
	240.89	5.9	0.24	350	6500				
	297.21	4.8	0.19	350	6500				

TKM58.. Performance (n ₁ with 4 pole 1400 rpm motor, sf = 1)						500Nm			
Ref	Ratio	n ₂ (rpm)	kW	M ₂ (Nm)	Fr ₂ (N)	71B5	80B5 80B14	90B5 90B14	100-112B5 & B14
2 Stage									
TKM58B	7.48	188	5.86	280	2950				
	9.84	143	5.73	360	3240				
	12.49	113	5.79	460	3510				
	15.09	93	5.18	500	3730				
	19.84	71	3.95	500	4090				
	25.19	56	3.12	500	4430				
	30.24	47	2.62	500	4710				
	40.13	35	1.95	500	5170				
	48.18	30	1.67	500	5500				
	59.04	24	1.23	460	5890				
3 Stage									
TKM58C	49.18	29	1.16	350	5540				
	62.43	23	1.18	450	6000				
	75.45	19	1.08	500	6390				
	99.22	15	0.85	500	7000				
	125.95	12	0.68	500	7580				
	151.2	9.3	0.53	500	8050				
	200.66	7.0	0.40	500	8300				
	240.89	5.9	0.34	500	8300				
	295.18	4.8	0.25	460	8300				

Section 5 TEC TKM Bevel Helical Gearbox

Installation - Dimensions

2 Stage

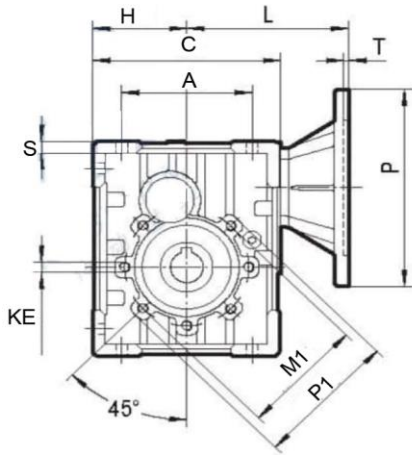

3 Stage

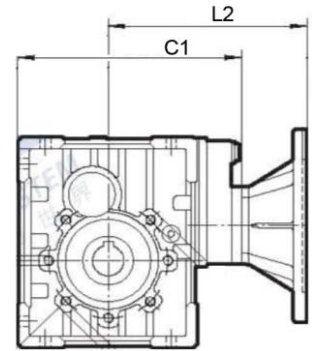
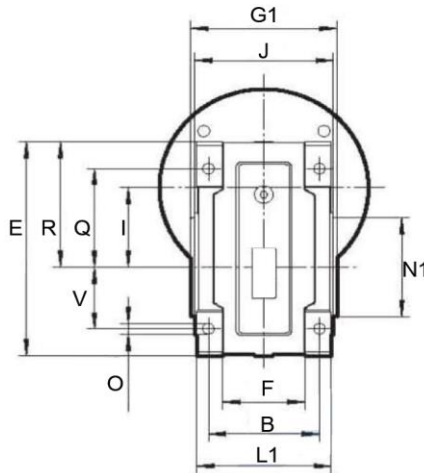

Output Flange

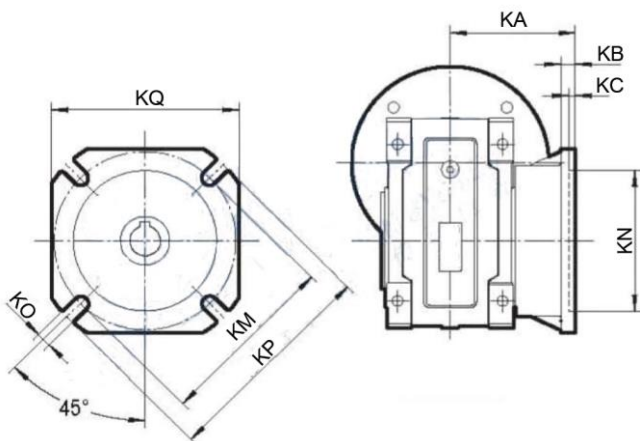

Input Flange

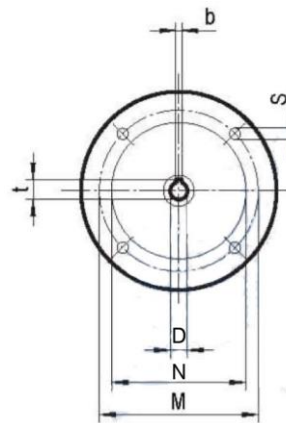

Output Hub

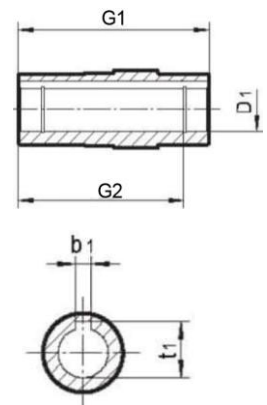

Ref	A	B	C	C ₁	D ₁ *	E	F	G ₁	G ₂	H	I 2stg	I 3stg	J	KE	L**	L ₁	L ₂ **	M ₁	N ₁
TKM28	80	70	121	155	24	155	51	92	77	60	57	57	87	M8	133	85	167	85	70
TKM38	100	85	144	178	25	174	63	112	97	72	64.5	29	106	M8	144	103	178	95	80
TKM48	120	90	173	213	28	205	68	120	105	86	74.5	30.5	114	M8	176	112	216	115	95
TKM58	140	100	205	246	35	238	74	140	122	103	88	44	134	M10	192	130	232	130	110

Ref	O	P ₁	Q	R	S	T	V	b ₁	t ₁	Kg
TKM28	8.5	100	75	95	7	4	40	8	27.3	4.2
TKM38	8.5	110	80	102	9	4	50	8	28.3	6.5
TKM48	11.5	140	93	119	10	4	60	8	31.3	10
TKM58	13.0	160	102	135	11	4.5	70	10	38.3	13

Ref	D1 std	* D1 Bore Options
TKM28	24	20 25
TKM38	25	28
TKM48	28	30 35
TKM58	35	38

Output Flange Dimensions	
Ref	KA KP KM KN KQ KB KC KO
TKM28	FA 90 125 85 70 110 9 5 11
	FB 120 125 85 70 110 9 5 11
	FC 89 160 130 110 146 10 5 9.5
	FD 72 140 115 95 130 14.5 5 11
TKM38	FA 82 180 150 115 142 10 6 11
	FB 112 180 150 115 142 10 6 11
	FC 98 200 165 130 180 10 5 11
	FD 107 200 165 130 180 10 5 11
TKM48	FA 111 200 165 130 170 13 6 14
	FB 90 160 130 110 160 13 6 11
TKM58	FA 111 210 175 152 200 13 6 14
	FB 122 250 215 180 230 18 6 14
	FC 110 200 165 130 200 17 6 11
	FD 151 210 175 152 200 13 6 14

Input Motor Flange Dimensions							
Ref	D	P	M	N	b	s	t
63B5	11	140	115	95	4	9	12.8
71B14	14	105	85	70	5	7	16.3
71B5	14	160	130	110	5	9	16.3
80B14	19	120	100	80	6	7	21.8
80B5	19	200	165	130	6	11	21.8
90B14	24	140	115	95	8	9	27.3
90B5	24	200	165	130	8	11	27.3
100B14	28	160	130	110	8	9	31.3
100B5	28	250	215	180	8	13.5	31.3
112B14	28	160	130	110	8	9	31.3
112B5	28	250	215	180	8	13.5	31.3

L/L₂** is the maximum length when fitted with largest frame motor.

Accessories - Dimensions

TKM..B..HS

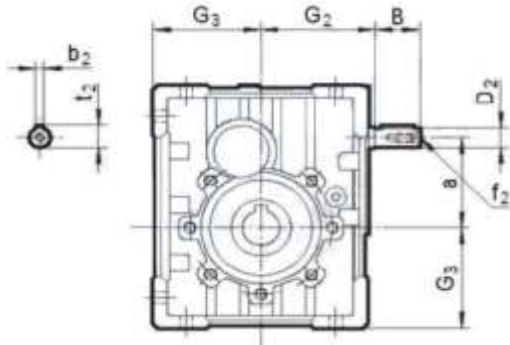

TKM..C..HS

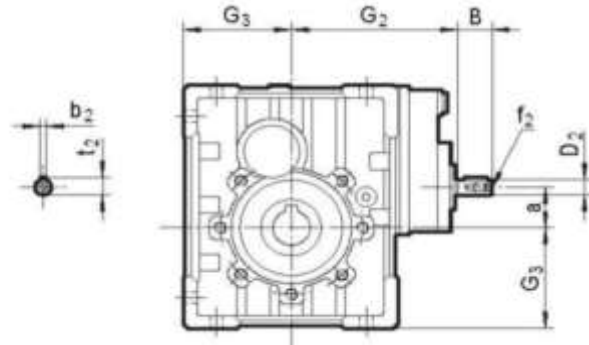

TKM...HS Solid Input Shaft

	B	D2 j6	G2	G3	a	b2	f2	t2
TKM28B	23	11	65	60	57	4	...	12.5
TKM28C	23	11	100	60	21.5	4	...	12.5
TKM38B	30	14	76	72	64.5	5	M6	16
TKM38C	23	11	111	72	29	4	...	12.5
TKM48B	40	16	91	86	74.5	5	M6	18
TKM48C	30	14	132	86	30.5	5	M6	16
TKM58B	40	19	107	103	88	6	M6	21.5
TKM58C	30	14	148	103	44	6	M6	16

Output shafts

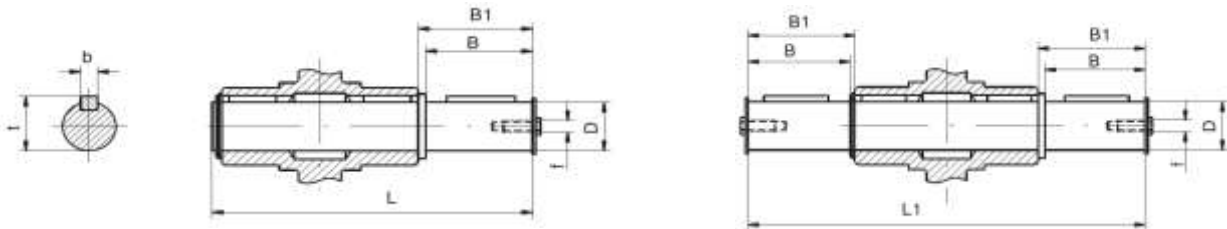

Ref	D h6	B	B1	L	L1	f	b	t
TKM28	24	50	53.5	153	199	M10x22	8	27.5
TKM38	25	50	53.5	173	219	M10x22	8	28
TKM48	28	60	63.5	192	247	M10x22	8	31
TKM58	35	80	84.5	234	309	M12x28	10	38

Torque Arm

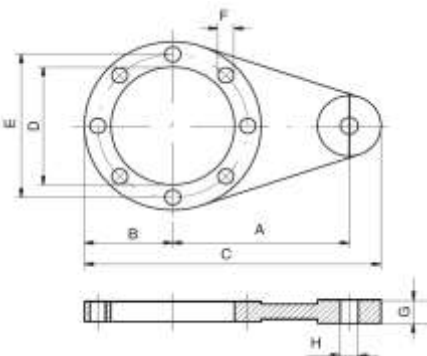

Ref	A	B	C	D	E	F	G	H
TKM28	100	50	168	70	85	9	14	10
TKM38	150	55	223	80	95	9	14	10
TKM48	200	70	300	95	115	9	25	20
TKM58	200	80	310	115	130	11	25	20

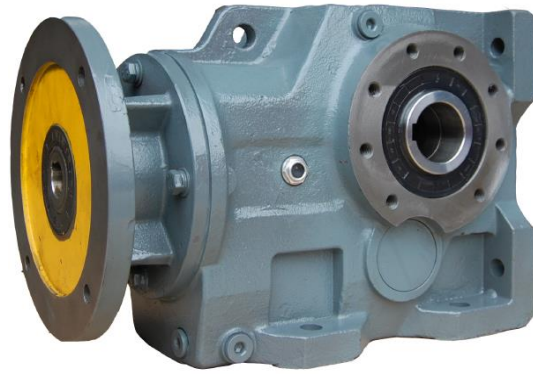

**WKAZ... UNIVERSAL MOUNT BEVEL HELICAL
GEAR BOX**

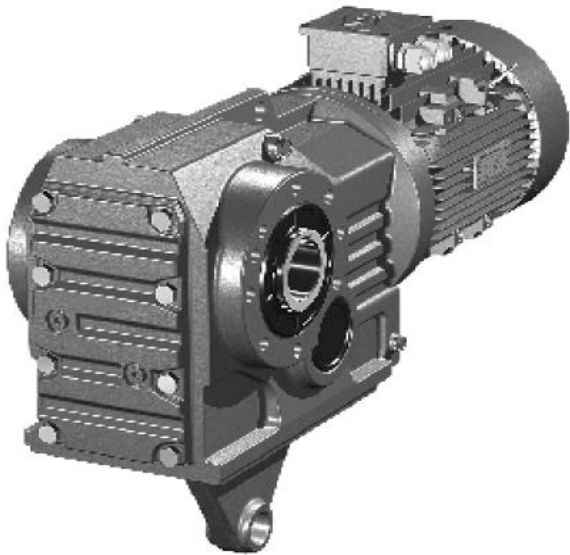

**WKAT... TORQUE ARM MOUNTED
BEVEL HELICAL GEARED MOTOR**

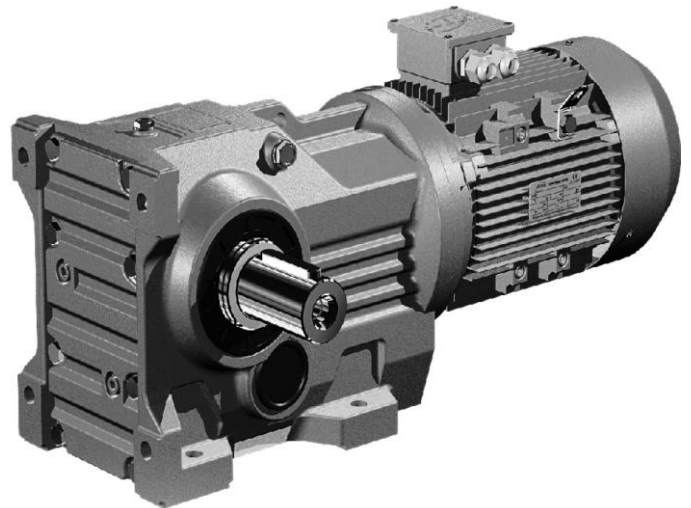

**WK... FOOT MOUNTED BEVEL HELICAL
GEARED MOTOR**

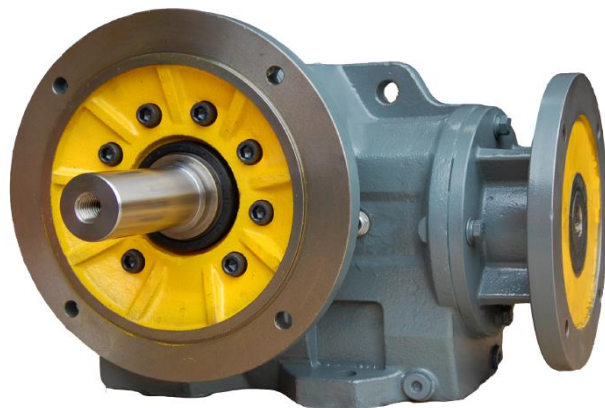

**WK... FLANGE MOUNTED BEVEL HELICAL GEAR
BOX**

Section 6 TEC WK Bevel Helical Gearbox

Summary

WK heavy duty series helical bevel gear units have been designed based on the modular format system. All types of IEC motors can be fitted. The versatility of the design lends itself to all types of mounting, apart from the two largest sizes. Housings are made from cast iron and gears made from high quality hardened steel. Torque range from 820 - 50000 Nm.

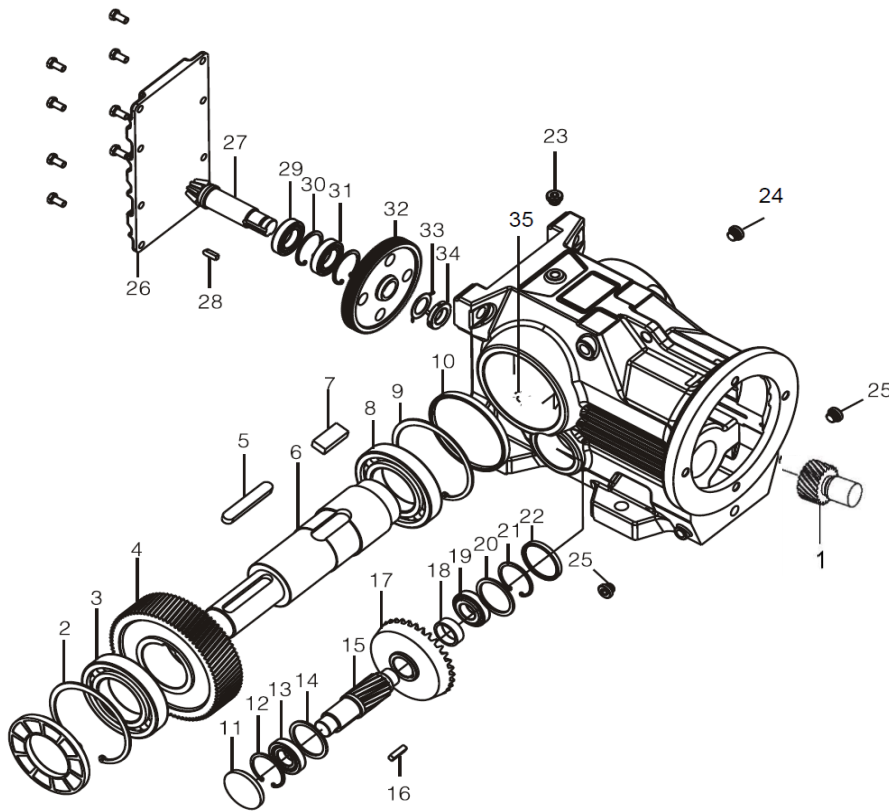

No.	Main Parts
1	Helical pinion (1 stage)
3	Output Bearing
4	Helical gear (3 stage)
6	Output hub/shaft
8	Output Bearing
10	Oil seal RCA
11	Oil seal RCA
13	Bearing
15	Helical pinion (3 stage)
17	Bevel gear (2 stage)
23	Oil filler plug
24	Oil level plug
25	Oil drain plug
26	Housing cover
27	Bevel pinion (2 stage)
29	Bearing
31	Bearing
32	Helical gear (1 stage)
33	Lock washer
35	Housing

Mounting positions

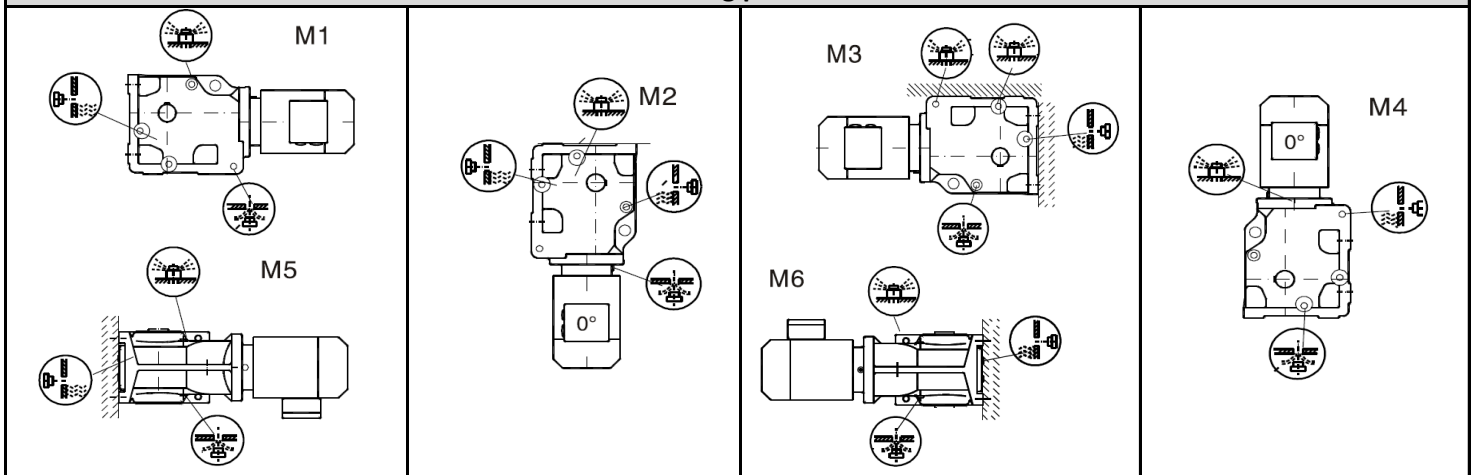

Oil fill quantity in litres

Mtg	WK66	WK76	WK86	WK96	WK106	WK126	WK156	WK166	WK186
M1	1.1	1.9	3.2	6.1	6.5	10.8	17.2	31.0	56.0
M2	2.2	3.6	7.0	12.2	13.2	21.3	34.4	88.0	155.0
M3	2.4	3.9	7.6	13.7	16.0	22.6	36.0	88.0	155.0
M4	3.2	5.2	9.5	17.5	21.0	27.7	50.0	110.0	190.0
M5	2.5	3.7	6.8	13.7	15.0	20.5	32.2	75.0	120.0
M6	2.5	3.9	7.0	14.0	15.0	21.0	34.4	75.0	120.0

The specified quantities are a recommended value, however amount can vary slightly by ratio due to the size of the gears, so it is essential to check the oil level plug for precise amount. If not specified units will be supplied as B3

Recommended lubricant mineral oil ISO VG220

Section 6 TEC WK Bevel Helical Gearbox

Performance (n1 with 4 pole motor)

Ref	Ratio	n2 (rpm)	kW	M2 (Nm)	Fr2 (N)	Motor input options all IECB5						
						63	71	80	90	100-112	132	
WK66	8.37	173	8.4	440	11100							
	10.63	136	7.5	500	11800							
	12.48	116	6.8	530	12300							
	15.19	95	7.4	700	11300							
	19.29	73	6.2	760	10800							
	23.99	60	5.3	800	10500							
	30.21	48	4.4	820	10300							
	38.39	38	3.5	820	10500							
	48.77	30	2.7	820	10300							
	60.66	24	2.2	820	10300							
	68.95	21	1.9	820	10300							
	76.37	19	1.7	820	10300							
90.04	16	1.5	820	10300								
108.03	13	1.2	820	10300								
123.54	11.0	1.0	820	10300								
WK76	8.46	170	16.8	890	13500		71	80	90	100-112	132	160
	10.81	133	14.6	990	14400							
	15.84	91	14.1	1400	15500							
	20.24	70	11.7	1500	15700							
	25.61	55	9.5	1550	15400							
	30.88	46	7.9	1550	15400							
	40.04	35	6.0	1550	15400							
	51.18	28	4.8	1550	15400							
	64.76	22	3.8	1550	15400							
	73.99	19	3.3	1550	15400							
	88.97	16	2.7	1550	15400							
	97.05	15	2.6	1550	15400							
113.56	12	2.1	1550	15400								
128.52	11	1.9	1550	15400								
154.02	9.0	1.5	1550	15400								
WK86	8.29	176	27.3	1400	13500		80	90	100-112	132	160	180
	11.16	131	21.8	1500	14900							
	14.44	101	23.5	2100	15300							
	19.45	75	19.1	2300	16800							
	24.92	59	16.4	2500	18000							
	31.38	47	14.1	2700	19200							
	44.02	32	9.2	2600	22800							
	49.16	29	8.7	2700	23500							
	63.00	23	6.9	2700	26200							
	70.46	20	6.0	2700	27300							
	86.34	17	5.1	2700	27300							
	102.71	14	4.1	2700	27300							
115.82	12	3.6	2700	27300								
126.91	11	3.3	2700	27300								
147.33	9.6	2.9	2700	27300								
WK96	8.71	169	49.9	2660	15800		90	100-112	132	160	180	200
	10.41	141	44.9	2870	16400							
	13.85	106	50.6	4300	17800							
	18.96	77	36.8	4300	19100							
	24.74	59	28.2	4300	22000							
	30.81	47	22.4	4300	24500							
	41.87	35	16.7	4300	28300							
	56.55	25	11.9	4300	30000							
	62.55	23	11.0	4300	33800							
	77.89	18	8.6	4300	37100							
	86.52	17	8.1	4300	38800							
	93.80	15	7.2	4300	40000							
105.13	14	6.7	4300	40000								
123.93	12	5.7	4300	40000								
140.28	10	4.8	4300	40000								
WK106	8.69	169	76.3	4070	24600		100-112	132	160	180	200	225
	11.73	125	58.3	4200	25800							
	14.63	100	76.5	6890	19500							
	19.74	74	59.1	7200	23200							
	26.32	56	44.8	7200	28800							
	32.68	45	36.0	7200	33200							
42.33	34	27.9	7400	37900								

Section 6 TEC WK Bevel Helical Gearbox

Performance (n1 with 4 pole motor)						
Ref	Ratio	n2 (rpm)	kW	M2 (Nm)	Fr2 (N)	Motor input options all IECB5
						100-112 132 160 180 200 225
WK106	49.90	29	25.1	7800	39300	
	66.52	22	19.5	8000	45400	
	73.30	19	17.0	8000	47900	
	90.96	16	14.2	8000	53500	
	100.75	14	12.3	8000	56200	
	112.41	13	11.5	8000	59300	
	121.46	12	10.2	8000	61500	
143.47	9.9	8.8	8000	65000		
WK126	8.68	169	135.6	7230	32500	132 160 180 200-225 250-280 315
	10.74	137	121.7	8000	33900	
	14.37	102	137.0	12100	31000	
	21.17	70	101.0	13000	37200	
	27.72	53	76.5	13000	43000	
	31.41	47	67.8	13000	45900	
	40.25	37	53.4	13000	52000	
	47.80	31	44.7	13000	56500	
	54.07	27	39.0	13000	59900	
	62.70	23	33.2	13000	64000	
	71.06	21	30.3	13000	67700	
	90.03	16	23.1	13000	75100	
	110.35	13	18.8	13000	79200	
122.67	12	17.3	13000	79200		
146.20	9.8	14.1	13000	79200		
WK156	12.66	117	220.8	17000	36700	132 160 180 200-225 250-280 315
	14.92	99	197.8	18000	38200	
	18.37	80	159.8	18000	43200	
	21.31	69	137.9	18000	47000	
	23.95	61	121.9	18000	50000	
	31.3	47	93.9	18000	57500	
	38.02	39	77.9	18000	63400	
	54.29	27	53.9	18000	74900	
	61.02	24	47.9	18000	79000	
	70.38	21	42.0	18000	84200	
	79.75	18	36.0	18000	88900	
	91.65	16	32.0	18000	94400	
	100.22	14	28.0	18000	98000	
122.39	12	24.0	18000	106500		
150.41	9.6	19.2	18000	112200		
WK166	17.34	86	305.5	32000	67900	132 160 180 200-225 250-280 315
	20.32	73	259.3	32000	74000	
	24.52	61	216.7	32000	81700	
	28.77	52	184.7	32000	88600	
	32.25	46	163.4	32000	93700	
	36.61	40	142.1	32000	99700	
	42.89	34	120.8	32000	107400	
	51.77	28	99.5	32000	11700	
	60.74	24	85.2	32000	125600	
	68.07	22	78.1	32000	132000	
	78.14	19	67.5	32000	140100	
	87.86	17	60.4	32000	147200	
	109.83	13	46.2	32000	150000	
134.99	11	39.1	32000	150000		
164.50	8.9	31.6	32000	150000		
WK186	17.18	86	395.2	41400	80800	132 160 180 200-225 250-280 315
	20.15	74	360.6	43900	84000	
	24.18	61	322.3	47600	86800	
	27.92	53	294.1	50000	90200	
	33.23	45	249.7	50000	99100	
	38.57	39	216.4	50000	107200	
	45.50	33	183.1	50000	116600	
	53.36	28	155.4	50000	126100	
	64.04	23	127.6	50000	137600	
	73.96	20	111.0	50000	147000	
	88.00	17	94.3	50000	159000	
	102.16	14	76.1	50000	16900	
	129.69	11	59.9	50000	188200	
144.59	10	53.7	50000	190000		
165.21	8.9	49.4	50000	190000		

Installation - Dimensions

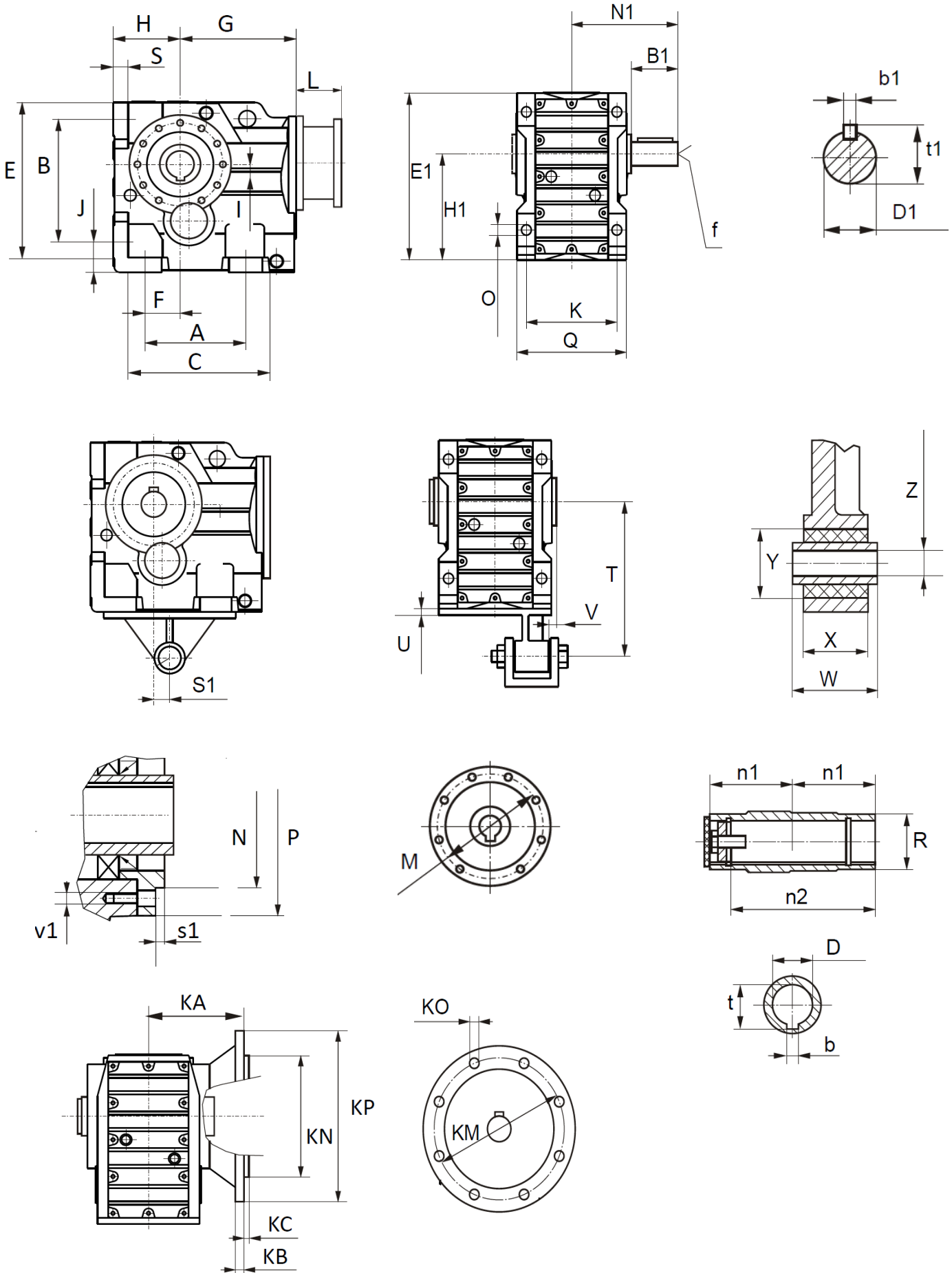

Installation - Dimensions

Size	A	B	B1	C	D	D1	E	E1	F	G	H	H1
WK...66	120	160	80	170	40	40	208	228	30	179	90	140
WK...76	150	200	100	208	50	50	263	288	40	202	112	180
WK...86	180	233	120	260	60	60	305	340	55	257	132	212
WK...96	240	295	140	294	70	70	372	417	75	277	160	265
WK...106	260	360	170	380	90	90	448	503	95	341	200	315
WK...126	350	420	210	440	100	110	526	592	115	390	225	375
WK...156	380	500	210	480	120	120	634	705	140	426	280	450
WK...166	540	540	250	737	140	160	736	786	200	522	315	500
WK...186	620	620	320	837	160	190	892	942	215	582	355	600

Size	I	J	K	L (max)	M	N	N1	O	P	Q	R	S
WK...66	20.0	45	140	123	125	105	171	13.5x8	155	170	55	24
WK...76	31.3	55	165	152.5	142	125	206	17.5x8	170	200	70	27
WK...86	25.9	70	180	147.5	178	155	240	22x8	215	230	85	32
WK...96	32.3	75	240	144.5	220	180	291	26x8	260	290	95	36
WK...106	52.0	95	270	168.5	260	210	347	33x8	304	340	118	40
WK...126	53.0	110	330	153.5	300	250	418	39x8	350	400	135	45
WK...156	71.7	130	420	175.5	340	290	457	39x8	400	500	155	50
WK...166	97.0	115	480	175.5	n/a	n/a	555	33x12	n/a	580	180	50
WK...186	112.0	140	540	175.5	n/a	n/a	657	39x12	n/a	640	200	50

Size	S1	T	U	V	W	X	Y	Z	b	b1	f	n1
WK...66	45	200	13	25	60	54	40	16.4	12	12	M16	90
WK...76	52.5	250	14	25	60	54	40	16.4	14	14	M16	105
WK...86	60	300	16	30	80	72	60	25	18	18	M20	120
WK...96	70	350	17	40	100	92	60	25	20	20	M20	150
WK...106	74	450	20	45	100	92	60	25	25	25	M24	175
WK...126	60	550	45	7	126	110	85	40	28	28	M24	205
WK...156	50	700	45	2	126	110	85	40	32	32	M24	250
WK...166	n/a	n/a	n/a	n/a	n/a	n/a	n/a	n/a	36	40	M30	305
WK...186	n/a	n/a	n/a	n/a	n/a	n/a	n/a	n/a	40	45	M30	337

Size	n2	s1	t	t1	v1	KA	KB	KC	KM	KN	KO	KP
WK...66	156	3.5	43.3	43.0	M12x7	113	15	4	215	180	13.5x4	250
WK...76	183	3.5	53.8	53.5	M12x7	142	16	4	265	230	13.5x4	300
WK...86	210	4.0	64.4	64.0	M16x6	150	18	5	300	250	17.5x4	350
WK...96	270	4.0	74.9	74.5	M16x8	191.5	22	5	400	350	17.5x8	450
WK...106	313	4.0	95.4	95.0	M20x8	216	22	5	400	350	17.5x8	450
WK...126	373	5.0	106.4	116.0	M20x11	256	25	5	500	450	17.5x8	550
WK...156	460	5.0	127.4	127.0	M24x10	310	28	6	600	550	22x8	660
WK...166	560	n/a	148.4	169.0	n/a	n/a	n/a	n/a	n/a	n/a	n/a	n/a
WK...186	624	n/a	169.4	200.0	n/a	n/a	n/a	n/a	n/a	n/a	n/a	n/a

Weight (kg) without oil									
WK...66	WK...76	WK...86	WK...96	WK...106	WK...126	WK...156	WK...166	WK...186	
33	45	81	150	230	420	680	1050	1650	

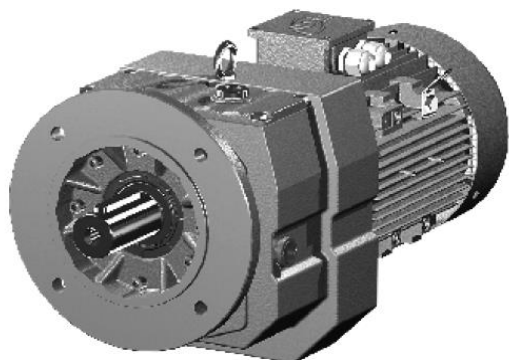

WRF... FLANGE MOUNTED HELICAL IN-LINE GEARED MOTOR

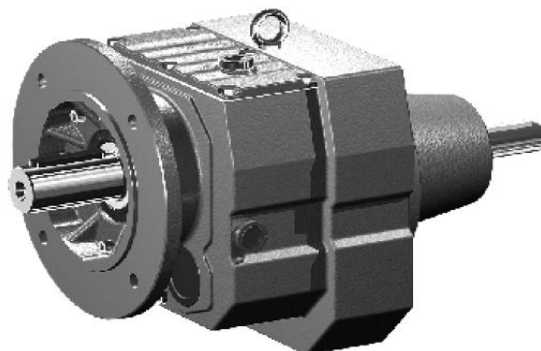

WRF...S FLANGE MOUNTED HELICAL IN-LINE REDUCER

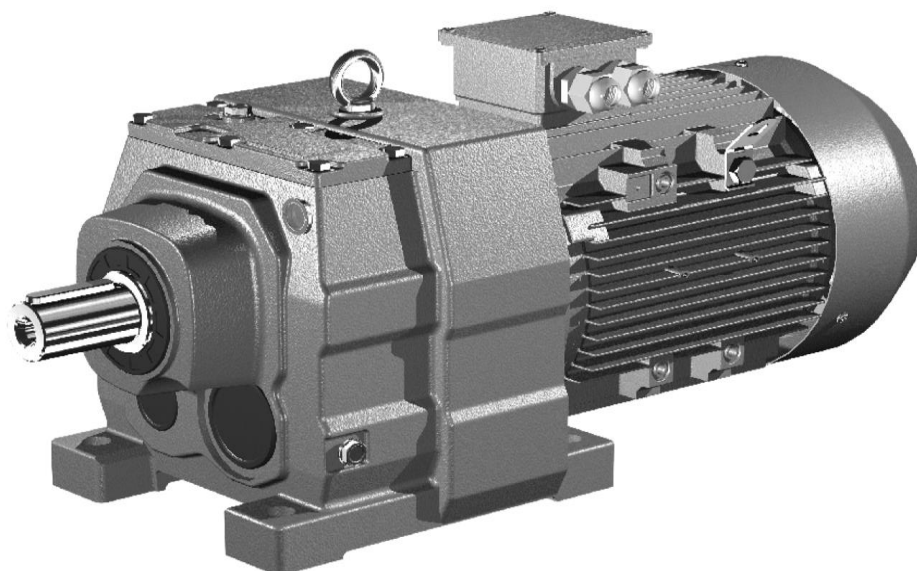

WR... FOOT MOUNTED HELICAL IN-LINE GEARED MOTOR

Summary

WR heavy duty series helical gear units have been designed based on the modular format system. All types of IEC motors can be fitted. The products can be mounted in six different orientations. Housings are made from cast iron and gears made from high quality hardened steel. Torque range from 1550 - 18000 Nm.

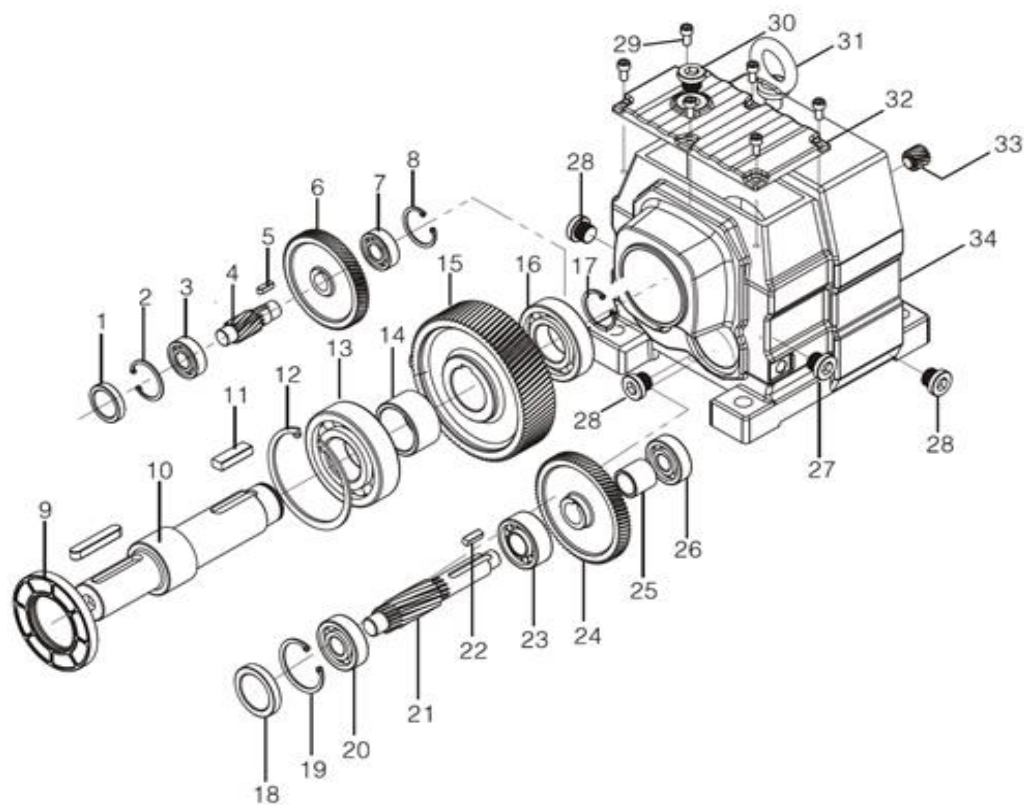

No.	Main Parts
3	Output Bearing
4	Helical pinion (3rd stg)
6	Helical gear (2nd stg)
7	Bearing
9	Output oil seal
10	Output shaft
13	Bearing
15	Helical gear (3rd stg)
16	Bearing
21	Helical pinion (2nd stg)
23	Bearing
24	Helical gear (1st stg)
26	Bearing
27	Oil level plug
28	Oil drain plug
30	Oil filler plug
31	Eye bolt
32	Housing cover
33	Helical pinion (1st stg)
34	Housing

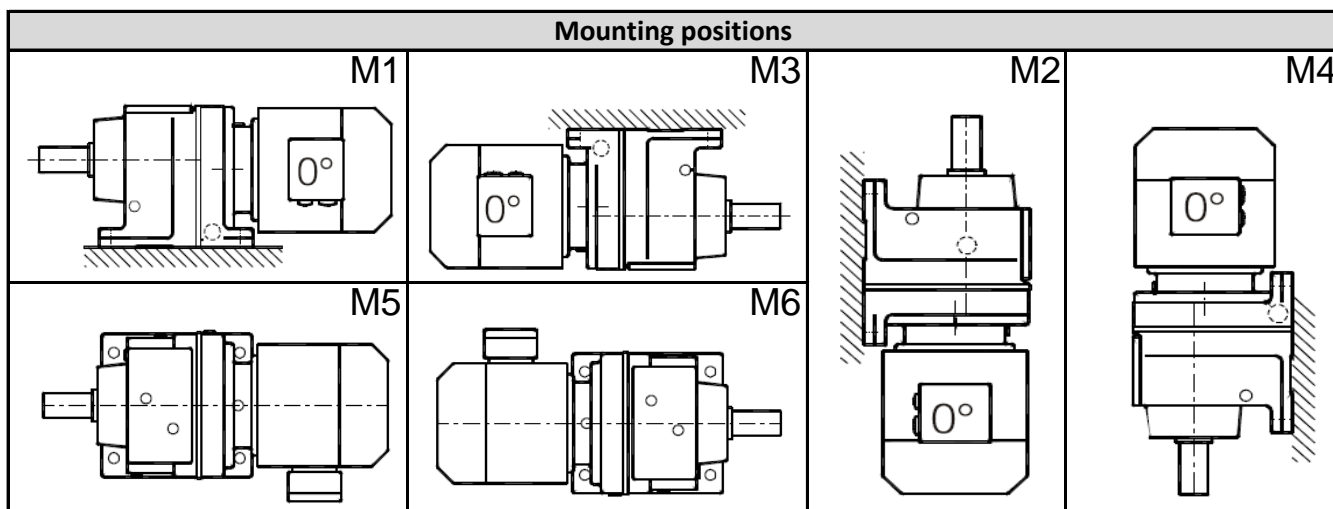

Oil fill quantity in litres						
Mtg	WR86	WR96	WR106	WR136	WR146	WR166
M1	6.0	10.2	14.9	25.0	42.0	70.0
M2	7.9	14.0	15.9	27.0	47.0	82.0
M3	7.1	11.2	17.0	29.0	48.0	78.0
M4	7.7	14.0	19.2	32.5	52.0	88.0
M5	6.3	11.2	13.1	25.0	42.0	65.0
M6	6.4	11.8	15.9	25.0	42.0	71.0

The specified quantities are a recommended value, however amount can vary slightly by ratio due to the size of the gears, so it is essential to check the oil level plug for precise amount. If not specified units will be supplied as B3

Recommended lubricant mineral oil ISO VG220

Section 7 TEC WR Helical Gearbox

Performance (n1 with 4 pole motor sf = 1)

Ref	Ratio	n2 (rpm)	kW	M2 (Nm)	Fr2 (N)	Motor input options all IECB5					
						80	90	100-112	132	160	180
WR86	7.13	209	24.4	1070	9780						
	9.90	144	18.5	1180	10400						
	11.93	119	15.9	1230	11200						
	13.33	107	14.9	1280	11600						
	17.08	83	12.6	1390	12600						
	21.51	66	10.8	1500	13600						
	27.84	51	8.6	1550	15000						
	32.66	43	7.4	1550	16000						
	41.74	34	5.8	1550	16900						
	52.82	27	4.6	1550	13500						
	60.35	24	4.1	1550	15200						
	72.57	19	3.3	1550	16900						
	81.92	17	2.9	1550	16900						
	93.38	15	2.6	1550	16900						
	103.65	14	2.4	1550	16900						
	124.97	11	1.9	1550	16900						
155.34	9.1	1.6	1550	16900							
181.77	7.8	1.3	1550	16900							
205.71	6.8	1.2	1550	16900							
246.54	5.5	0.9	1550	16900							
WR96	7.12	206	44.9	2000	10900						
	9.29	158	34.9	2030	12200						
	12.39	118	28.1	2190	12700						
	14.62	100	25.0	2300	13400						
	16.17	91	23.8	2400	13800						
	20.14	71	20.2	2610	14800						
	25.03	57	17.6	2830	15900						
	33.25	43	13.8	2890	17900						
	42.78	33	11.0	3000	19800						
	53.21	27	9.0	3000	19800						
	65.21	22	7.3	3000	19800						
	72.17	20	6.7	3000	19800						
	83.15	17	5.7	3000	19800						
	92.48	15	5.0	3000	19800						
	103.44	14	4.7	3000	19800						
	126.75	11	3.7	3000	19800						
	150.78	9.3	3.1	3000	19800						
	186.30	7.6	2.5	3000	19800						
216.28	6.5	2.2	3000	19800							
255.71	5.5	1.8	3000	19800							
WR106	7.86	186	58.7	2900	13900						
	10.13	245	99.8	3740	13300						
	13.66	107	50.1	4300	14400						
	15.65	94	44.0	4300	15400						
	20.07	73	34.2	4300	18300						
	24.90	59	27.6	4300	19200						
	30.77	50	23.4	4300	21100						
	35.26	42	20.0	4300	22400						
	40.37	36	17.2	4300	23800						
	52.68	27	12.9	4300	26600						
	65.60	22	10.5	4300	29200						
	72.88	20	9.5	4300	29500						
	78.57	18	8.6	4300	29500						
	92.70	15	7.2	4300	29500						
	102.53	14	6.7	4300	29500						
	127.68	11	5.3	4300	29500						
	141.83	10	4.8	4300	29500						
	172.34	8.2	3.9	4300	29500						
	203.16	6.9	3.3	4300	29500						
251.15	5.6	2.7	4300	29500							

2 Reduction stages

3 Reduction stages

Section 7 TEC WR Helical Gearbox

Performance (n1 with 4 pole motor sf = 1)

Ref	Ratio	n2 (rpm)	kW	Mz (Nm)	Fr2 (N)	Motor input options all IECB5					
						132	160	180	200	225	250-280
WR136	7.59	194	97.2	4600	41100						
	10.79	137	107.4	7200	34700						
	14.51	102	88.9	8000	37300						
	19.04	77	67.1	8000	43500						
	24.12	61	53.1	8000	49400						
	32.91	45	40.0	8000	53400						
	37.65	39	34.6	8000	53400						
	44.39	33	29.3	8000	53400						
	50.86	29	25.8	8000	53400						
	59.17	25	22.2	8000	53400						
	73.49	20	17.8	8000	53400						
	80.91	18	16.0	8000	53400						
	88.70	16	14.2	8000	53400						
	103.20	14	12.4	8000	53400						
	128.18	11	9.8	8000	53400						
141.12	10	8.9	8000	53400							
156.31	9.1	8.1	8000	53400							
174.40	8.2	7.3	8000	53400							
188.45	7.6	6.7	8000	53400							
222.60	6.4	5.7	8000	53400							
WR146	7.25	197	186.0	8670	58400						
	9.76	151	213.8	13000	54400						
	13.93	106	145.4	12600	63400						
	15.66	94	133.1	13000	62700						
	20.47	72	94.1	12000	64600						
	24.23	61	80.6	11900	64700						
	30.00	49	70.7	13000	62700						
	35.69	41	59.2	13000	62700						
	40.35	36	51.9	13000	62700						
	46.73	32	46.2	13000	62700						
	52.96	28	40.4	13000	62700						
	61.19	24	34.6	13000	62700						
	67.09	22	31.7	13000	62700						
	72.20	20	28.9	13000	62700						
	83.60	17	24.5	13000	62700						
	94.75	15	21.6	13000	62700						
	109.48	13	18.8	13000	62700						
120.04	12	17.3	13000	62700							
147.14	9.9	14.3	13000	62700							
163.57	8.9	12.8	13000	62700							
WR166	10.24	145	268.4	17000	82500						
	11.99	123	227.7	17000	88700						
	14.48	102	199.9	18000	93800						
	16.98	87	142.1	15000	108900						
	19.03	77	134.2	16000	111400						
	23.71	60	119.9	18000	116500						
	27.97	53	105.9	18000	120000						
	34.41	43	85.9	18000	120000						
	39.92	37	73.9	18000	120000						
	44.87	33	65.9	18000	120000						
	51.76	29	57.9	18000	120000						
	67.40	22	44.0	18000	120000						
	73.70	20	40.0	18000	120000						
	82.91	18	36.0	18000	120000						
	93.19	16	32.0	18000	120000						
	107.49	14	28.0	18000	120000						
	121.81	12	24.0	18000	120000						
	153.07	9.6	19.2	18000	120000						
186.93	7.8	15.6	18000	120000							
229.71	6.4	12.8	18000	120000							

2 Reduction stages

3 Reduction stages

Installation - Dimensions

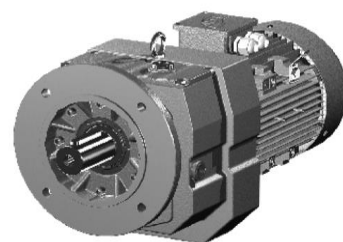
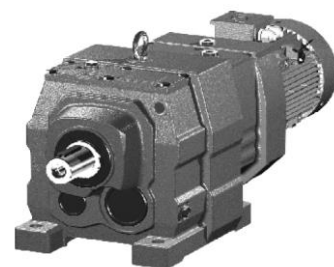
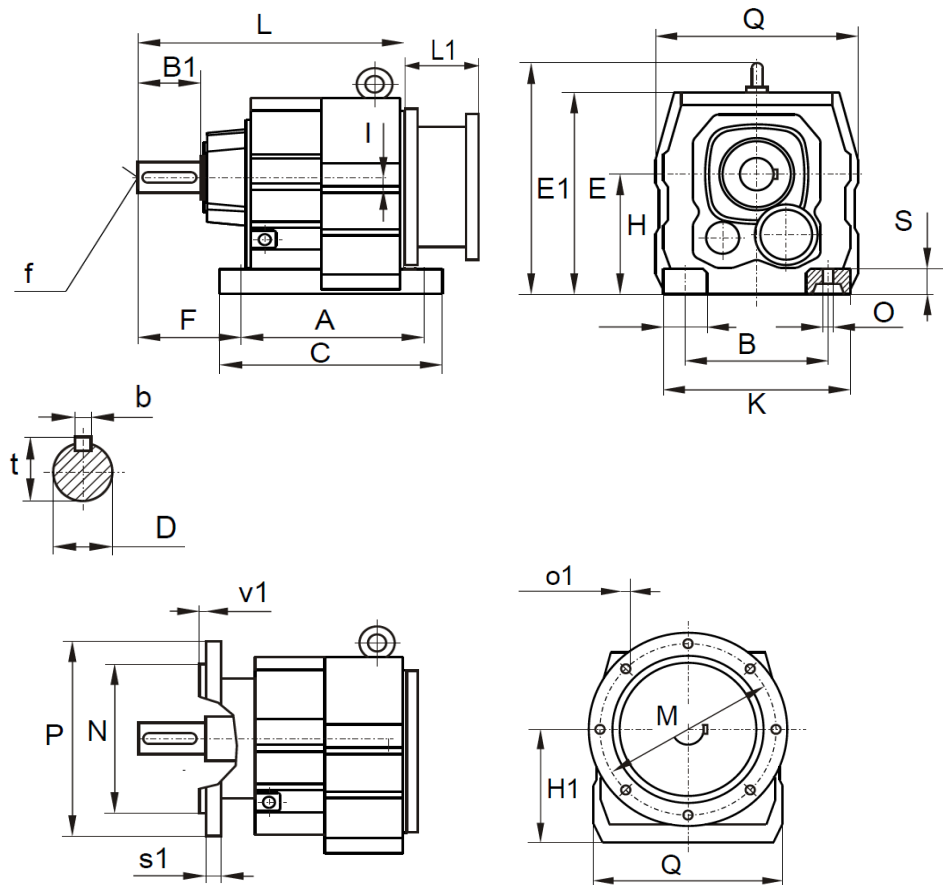

Size	A	B	B1	C	D	E	E1	F	f	H	H1	I	K
WR86	260	215	100	320	50	295	345	140	M16	180	180	12.6	290
WR96	310	250	120	365	60	368	418	160	M20	225	225	10.2	340
WR106	370	290	140	440	70	408	475	185	M20	250	250	20.4	400
WR136	410	340	170	490	90	495	562	220	M24	315	315	25.1	450
WR146	500	380	210	590	110	565	637	260	M24	355	355	33.4	530
WR166	580	500	210	670	120	675	749	270	M24	425	425	59.9	660

Size	L	L1 (max)	M	N	O	o1	P	Q	S	s1	v1	b	t
WR86	372	147.5	265	230	17.5	13.5x4	300	297	45	16	4	14	53.5
WR96	440	144.5	300	250	22	17.5x4	350	348	55	18	5	18	64.0
WR106	495	168.5	300	250	26	17.5x8	350	409	65	22	5	20	74.5
WR136	589	161.5	400	350	33	17.5x8	450	458	70	22	5	25	95.0
WR146	695	153.5	400	350	39	17.5x8	450	540	80	22	5	28	116.0
WR166	790	175.5	500	450	39	17.5x8	550	670	100	25	5	32	127.0

Weight (kg) without oil					
WR86	WR96	WR106	WR136	WR146	WR166
65	120	165	255	370	700

Section 8 Motors

Dimensions

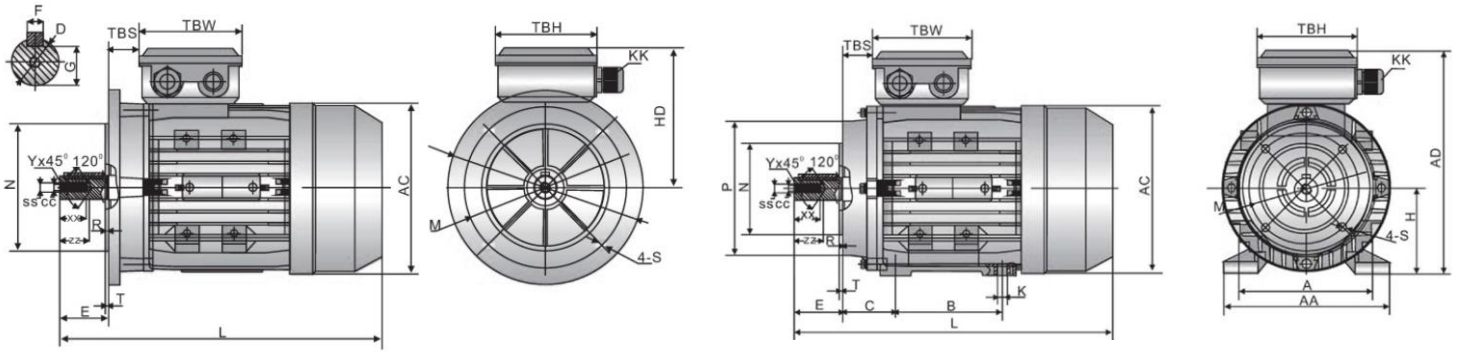

Frame	Foot B3 (B34,B35)						Shaft			General				B14			B5		
	A	AA	B	C	H	AD	D	E	F	AC	G	L	HD	N	M	P	N	M	P
56	90	110	71	36	56	156	9	20	3	117	7.2	196	100	50	65	80	80	100	120
63	100	120	80	40	63	171	11	23	4	130	8.5	220	108	60	75	90	95	115	140
71	112	132	90	45	71	186	14	30	5	147	11	241	115	70	85	105	110	130	160
80	125	160	100	50	80	213	19	40	6	163	15.5	290	133	80	110	120	130	165	200
90S	140	175	100	56	90	229	24	50	8	183	20	312	139	95	115	140	130	165	200
90L	140	175	125	56	90	229	24	50	8	183	20	367	139	95	115	140	130	165	200
100	160	198	140	63	100	252	28	60	8	205	24	369	152	110	130	160	180	215	250
112	190	220	140	70	112	279	28	60	8	229	24	395	167	110	130	160	180	215	250
132S	216	252	140	89	132	318	38	80	10	265	33	437	186	130	165	200	230	265	300
132M/L	216	252	178	89	132	318	38	80	10	265	33	501	186	130	165	200	230	265	300
160M	254	290	210	108	160	384	42	110	12	325	37	640	224	180	215	250	250	300	350
160L	254	290	254	108	160	384	42	110	12	325	37	640	224	180	215	250	250	300	350
180M	279	340	241	121	180	440	48	110	14	368	42.5	730	260				250	300	350
180L	279	340	279	121	180	440	48	110	14	368	42.5	730	260				250	300	350
200	318	390	305	133	200	460	55	110	16	368	49	745	260				300	350	400
225S	356	436	286	149	225	553	60	140	18	465	53	814	328				350	400	450
225M	356	436	311	149	225	553	60	140	18	465	53	839	328				350	400	450
250	406	384	349	168	250	616	65	140	18	506	58	918	366				450	500	550
280S	457	557	368	190	280	668	75	140	20	559	67.5	984	388				450	500	550
280M	457	557	419	190	280	668	75	140	20	559	67.5	1035	388				450	500	550
315S	508	630	406	216	315	845	80	170	22	680	71	1235	530				550	600	660
315M	508	630	457	216	315	845	80	170	22	680	71	1385	530				550	600	660

Cast iron

Terminal box position (relates to all types of units shown in mounting position B3/M1)

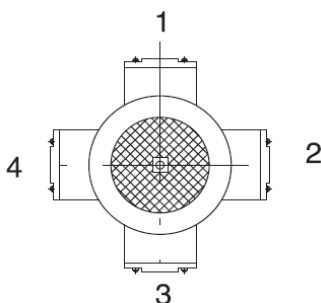

Notes



Notes

