



# MOTOR DATA SHEET

**MOTOR PART CODE:**

**1.123TECCB5-IE2**

**FRAME SIZE:**

**802-2**

	50Hz
Output (kW)	1.1
Rotation Speed (rpm)	2880
Voltage	230/400
Full Load Current (A)	4.21/2.43
Full Load Torque (Nm)	3.65

	60Hz
Output (kW)	1.32
Rotation Speed (rpm)	3456
Voltage	276/480
Full Load Current (A)	4.21/2.43
Full Load Torque (Nm)	3.04

## Efficiency Data

100%	75%	50%
79.6	80.5	78.6

Factory Reference	T2C 802-2
Tst/Tn (times)	2.5
Tmax/Tn	2.6
Noise (dB)	67
Moment of inertia	0.00119
Type of feet	Not fitted
Protection	IP55
Rotation Direction	F / R
Cable Glands	1 - M20× 1.5
Paint Colour	RAL 7024
Efficiency	IE2
Bearing (DE)	6204 2RS C3

Power Factor (cos)	0.82
Tmin/Tn	1.8
Ist/In (Times)	7.5
Net Weight (Kg)	16.5
Housing material	Cast Iron
Insulation Class	F
Thermal Protection	PTC 140°C
Duty Cycle	S1
Cooling	IC 411
Ambient Temperature	-20°C to +40°C
Bearing Brand	NSK
Bearing (NDE)	6204 2RS C3

*Motors designed and manufactured in accordance with:*

**IEC 60034  
IEC 60038  
IEC 60072  
2014/30/EU (EMC)  
2014/35/EU (LVD)  
2011/65/EU (RoHS 2)**

[www.tecmotors.co.uk](http://www.tecmotors.co.uk)

TEC Electric Motors Ltd. reserves the right to amend or change motor designs or data sheet information

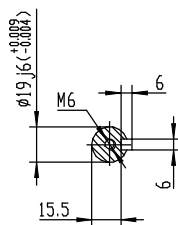
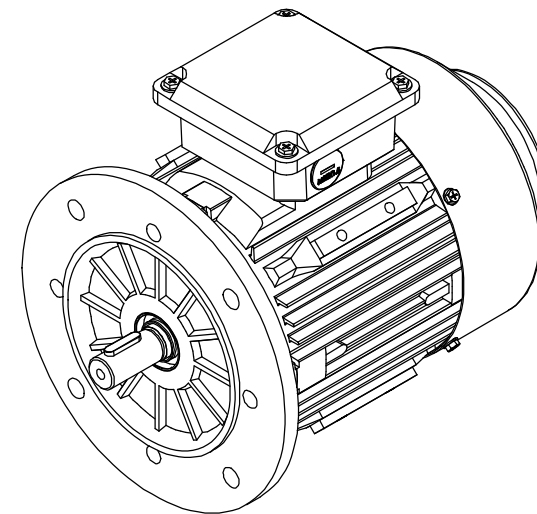
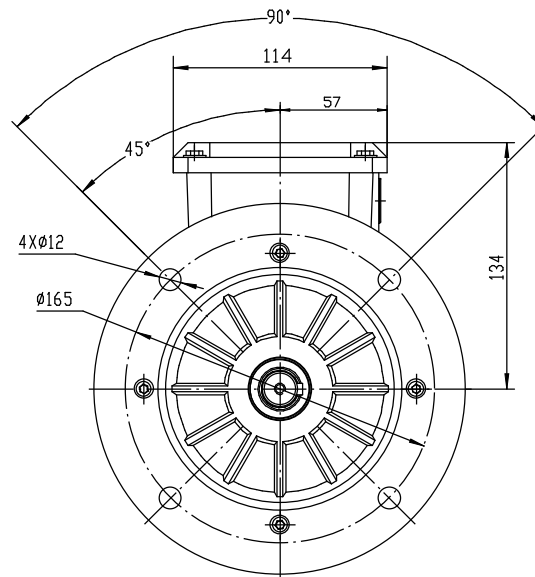
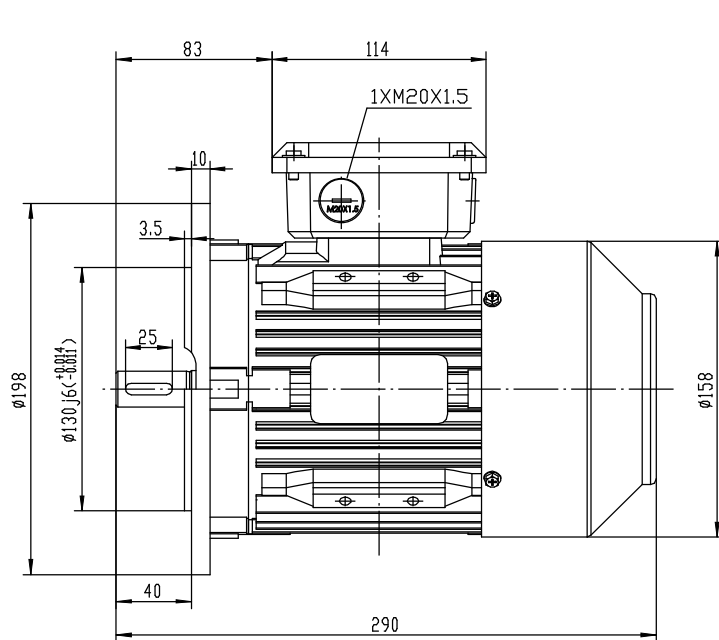

Drawn By	Date	<b>TC 80 B5</b>
A442313	27/11/2017	
Approved by	Date	 <a href="http://www.tecmotors.co.uk">www.tecmotors.co.uk</a>
L. Overton	27/11/2017	
Issue No =	Date	
BM01/A001	27/11/2017	