



MOTOR DATA SHEET

MOTOR PART CODE:

1.541TCCB35

FRAME SIZE:

90L-4

50Hz

Output (kW)	1.5
Rotation Speed (rpm)	1420
Voltage	230
Full Load Current (A)	8.56
Full Load Torque (Nm)	10.09

Factory Reference	ML90L-4
Tst/Tn (times)	2.5
Tmax/Tn	1.75
Noise (dB)	75
Moment of inertia	0.003252395
Type of feet	Removable feet
Rotation Direction	F / R
Cooling	IC411
Standard	IEC60034
IP Rating	IP55
Allowed Radial Load (N)	829
Bearing (DE)	6205 2RZ C3

Power Factor (cos)	0.97
Tmin/Tn	1.45
Ist/In (Times)	6.5
Net Weight (Kg)	16.7
Housing material	Aluminium
Insulation Class	F
Duty Cycle	S1
Paint	RAL 7024
Ambient Temperature	-20°C to +40°
Starting Method	DOL
Allowed Axial Load (N)	669
Bearing (NDE)	6205 2RZ C3

Motors designed and manufactured in accordance with:

IEC 60034
IEC 60038
IEC 60072
2014/30/EU (EMC)
2014/35/EU (LVD)
2011/65/EU (RoHS 2)

www.tecmotors.co.uk

TEC Electric Motors Ltd. reserves the right to amend or change motor designs or data sheet information

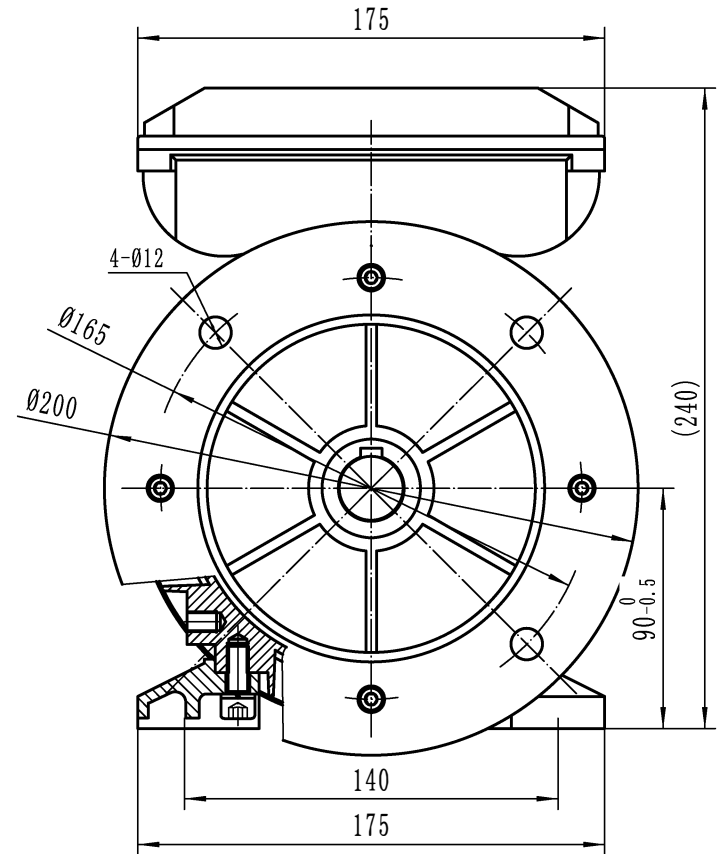
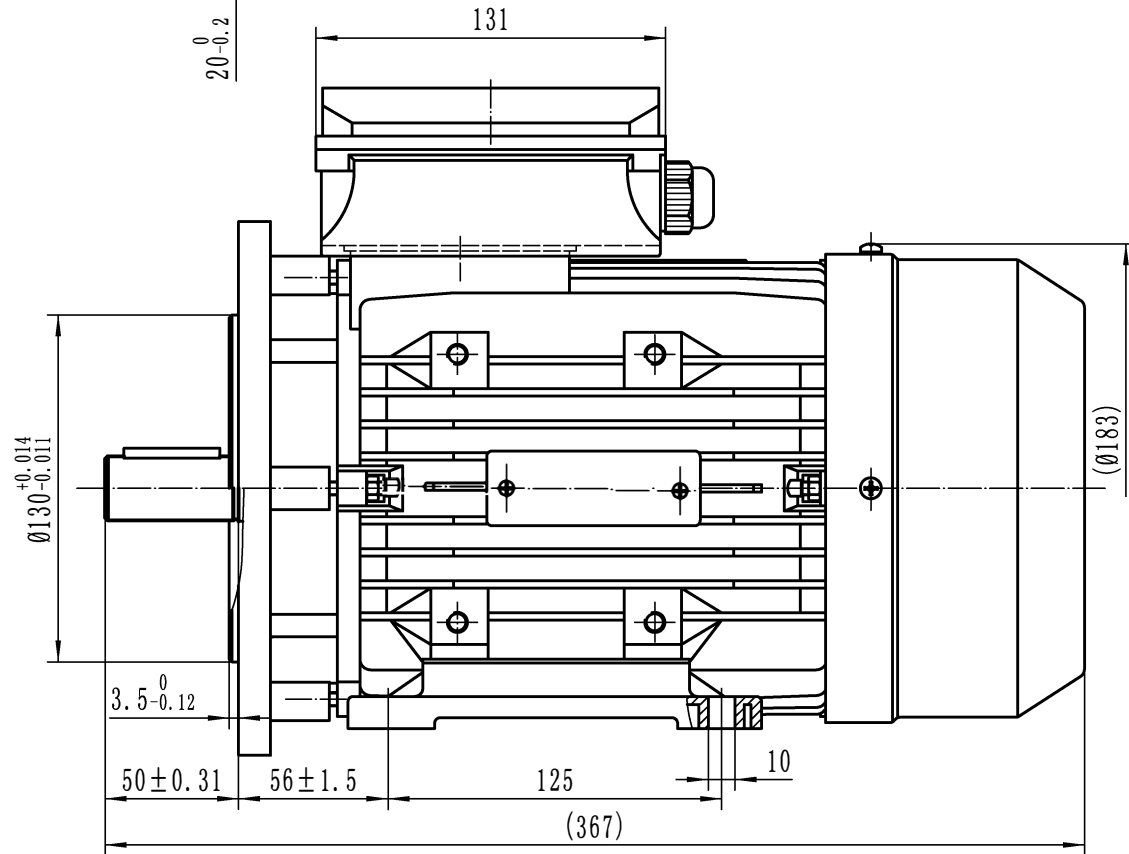
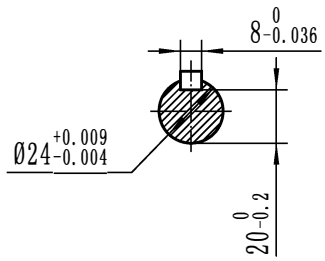

Drawn By	Date
A442313	27/11/2017
Approved by	Date
L. Overton	27/11/2017
Issue No =	Date
A401/18/001	27/11/2017

TCC 90L B35



www.tecmotors.co.uk