



# MOTOR DATA SHEET

**MOTOR PART CODE:**

**11.043TECAB3-132-IE2**

**FRAME SIZE:**

**132M3-4**

	50Hz
Output (kW)	11
Rotation Speed (rpm)	1460
Voltage	400/690
Full Load Current (A)	20.8   12.01
Full Load Torque (Nm)	71.95205479

	60Hz
Output (kW)	13.2
Rotation Speed (rpm)	1752
Voltage	480   828
Full Load Current (A)	20.8   12.01
Full Load Torque (Nm)	59.96

## Efficiency Data

100%	75%	50%
89.8	90.5	90.1

Factory Reference	T2A 132M3-4
Tst/Tn (times)	3.3
Tmax/Tn	3.6
Noise (dB)	75
Moment of inertia	0.05391993
Type of feet	Removable feet
Protection	IP55
Rotation Direction	F / R
Cable Glands	2 - M25× 1.5
Paint Colour	RAL 7024
Efficiency	IE2
Bearing (DE)	6308 2RS C3

Power Factor (cos)	0.85
Tmin/Tn	1.4
Ist/In (Times)	9.3
Net Weight (Kg)	66.2
Housing material	Aluminum
Insulation Class	F
Thermal Protection	PTC 130°C
Duty Cycle	S1
Cooling	IC411
Ambient Temperature	-20°C to +40°
Bearing Brand	NSK
Bearing (NDE)	6208 2RS C3

*Motors designed and manufactured in accordance with:*

**IEC 60034**  
**IEC 60038**  
**IEC 60072**  
**2014/30/EU (EMC)**  
**2014/35/EU (LVD)**  
**2011/65/EU (RoHS 2)**

[www.tecmotors.co.uk](http://www.tecmotors.co.uk)

TEC Electric Motors Ltd. reserves the right to amend or change motor designs or data sheet information

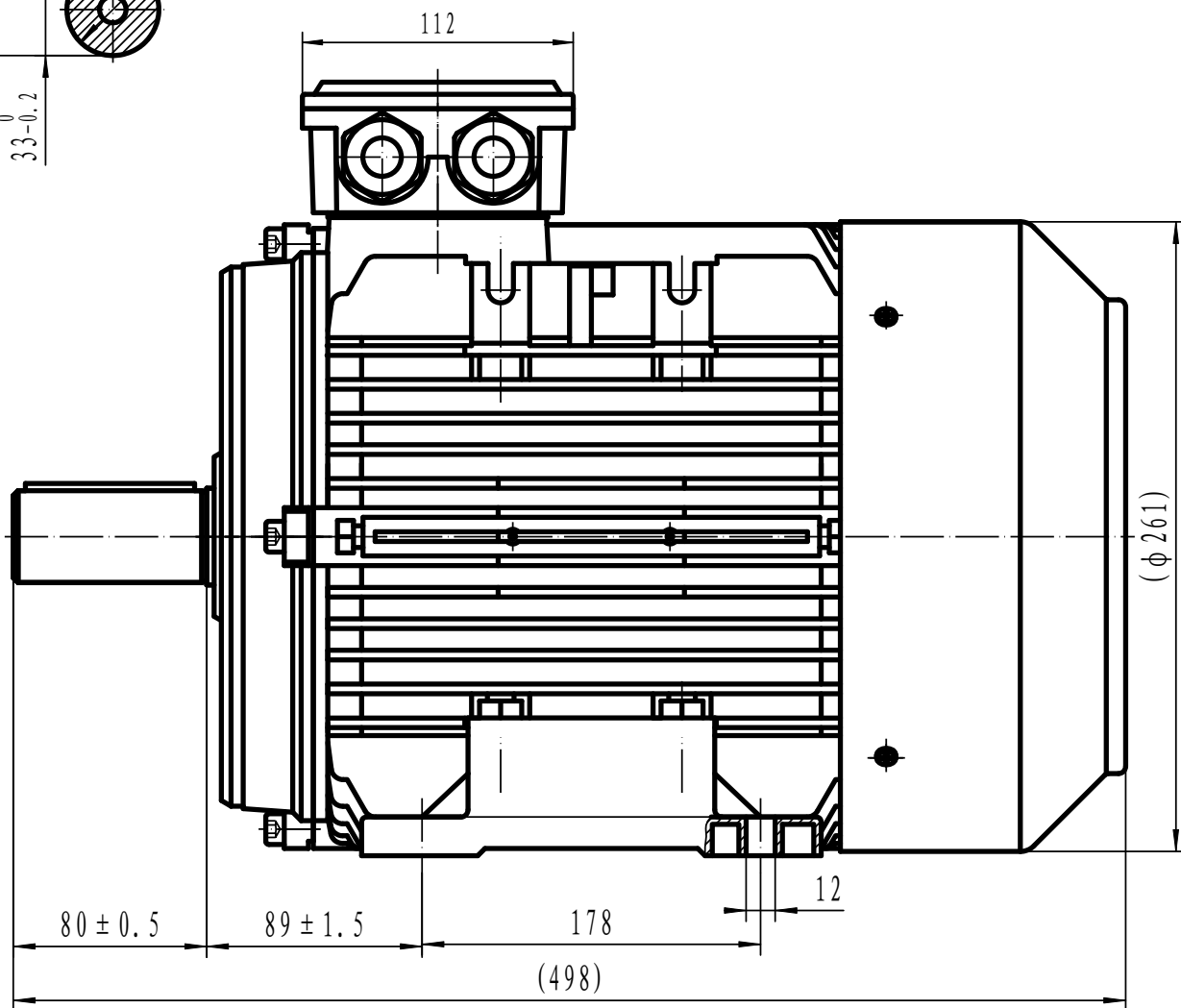
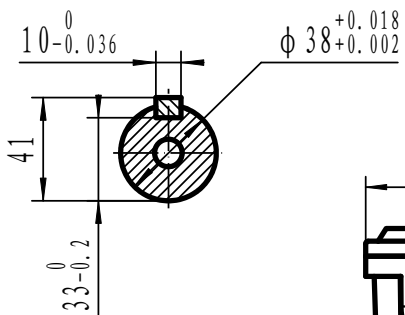

( $\phi 261$ )

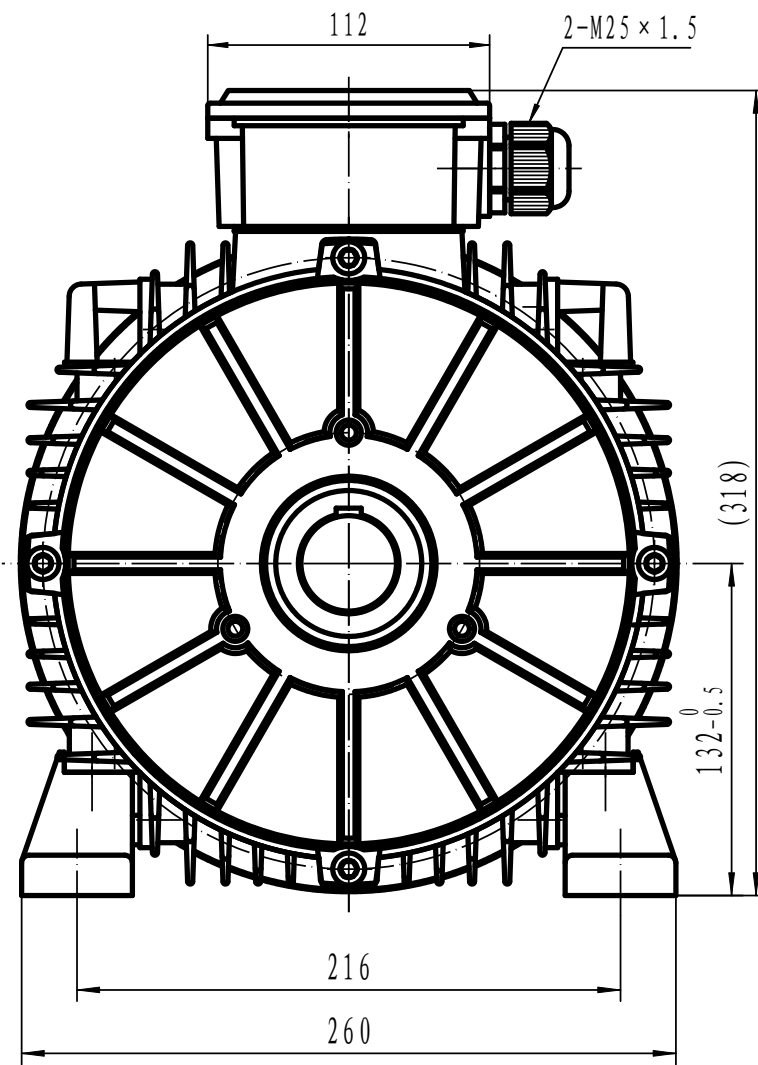

Drawn By	Date
TECHTOP	27/11/2017
Approved by	Date
L. Overton	27/11/2017
Issue No =	Date
001/A	27/11/2017

**TA132MB3**



[www.tecmotors.co.uk](http://www.tecmotors.co.uk)