



MOTOR DATA SHEET

MOTOR PART CODE:

90.043TECCB5-IE3

FRAME SIZE:

280M-4

	50Hz
Output (kW)	90
Rotation Speed (rpm)	1480
Voltage	400/690
Full Load Current (A)	160.53 92.68
Full Load Torque (Nm)	580.7

	60Hz
Output (kW)	108
Rotation Speed (rpm)	1776
Voltage	480 828
Full Load Current (A)	160.53 92.68
Full Load Torque (Nm)	483.92

Efficiency Data

100%	75%	50%
95.2	95.1	95

Factory Reference	T3C 280M-4
Tst/Tn (times)	2.5
Tmax/Tn	2.8
Noise (dB)	86
Moment of inertia	2.18345
Type of feet	Not Fitted
Protection	IP55
Rotation Direction	F / R
Cable Glands	2 - M50× 1.5
Paint Colour	RAL 7024
Efficiency	IE3
Bearing (DE)	6316 C3

Power Factor (cos)	0.85
Tmin/Tn	1.8
Ist/In (Times)	10
Net Weight (Kg)	692
Housing material	Cast Iron
Insulation Class	F
Thermal Protection	PTC 140°C
Duty Cycle	S1
Cooling	IC411
Ambient Temperature	-20°C to +40°C
Bearing Brand	NSK
Bearing (NDE)	6316 C3

Motors designed and manufactured in accordance with:

**IEC 60034
IEC 60038
IEC 60072
2014/30/EU (EMC)
2014/35/EU (LVD)
2011/65/EU (RoHS 2)**

www.tecmotors.co.uk

TEC Electric Motors Ltd. reserves the right to amend or change motor designs or data sheet information

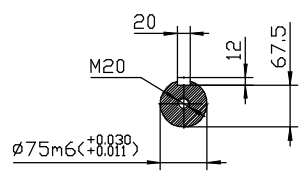
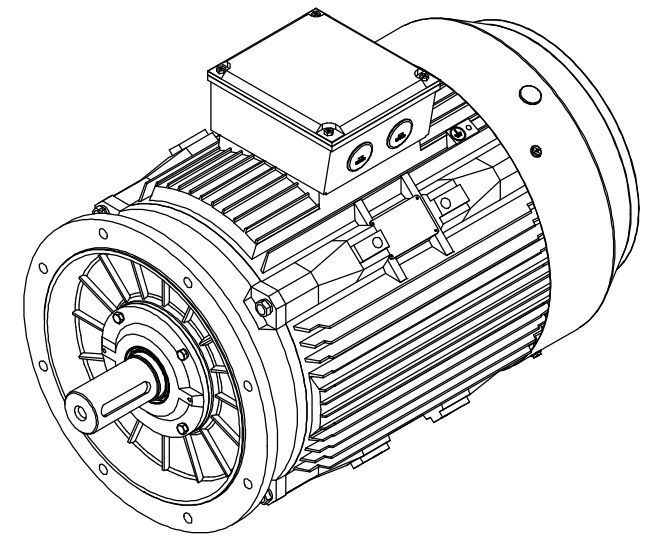
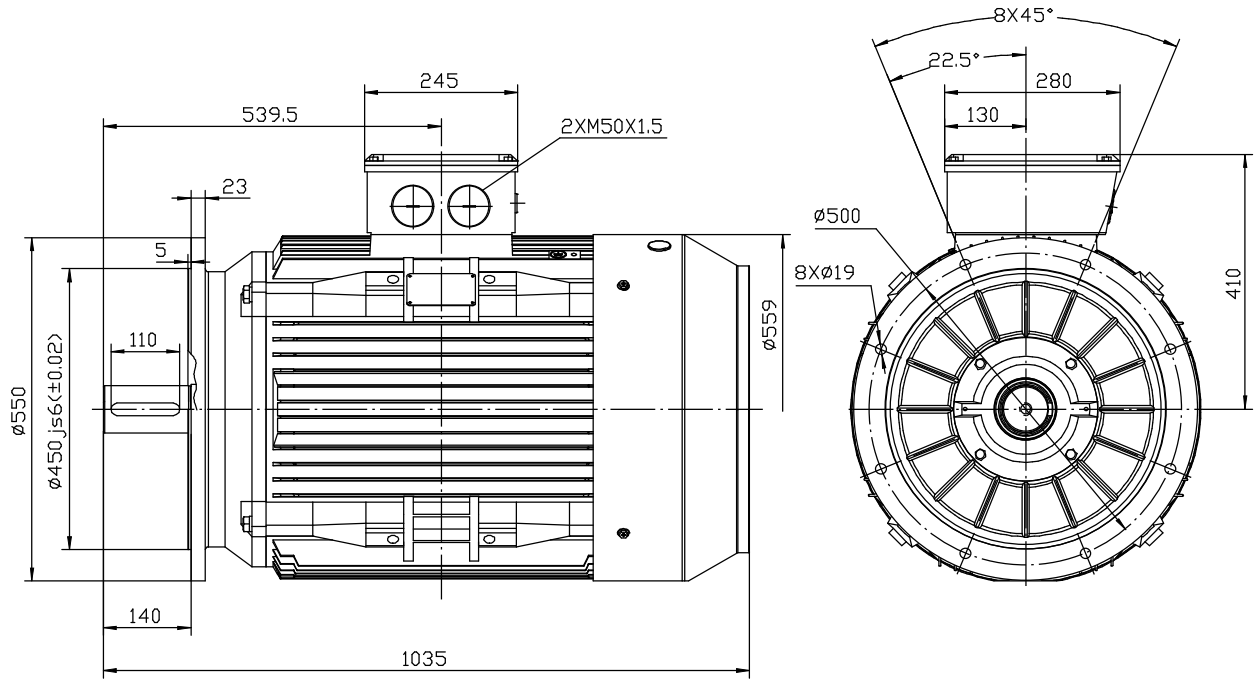

Drawn By	Date
A442313	27/11/2017
Approved by	Date
L. Overton	27/11/2017
Issue No =	Date
BM01/A001	27/11/2017

TC 280M B5

