

Trans-flat

Rubber Flat Belts



HIGH STRENGTH

LIGHTWEIGHT

HIGH FLEXIBILITY

CONSTANT THICKNESS

HIGH COEFFICIENT
OF FRICTION

INEXTENSIBLE



Trans-flat

Transflat® flat endless belt features

Enabling vibration-free drives, very high belt speeds, reduced dimensions, high performance and minimum maintenance.

Transflat® belts consist of a high strength core, endless fabric and a Rubber carcass with excellent mechanical properties and a high coefficient of friction.

Construction

Nylon reinforced Polychloroprene Rubber.

Applications

Typical applications for Transflat® Flat belts include conveyors, machine tools, and other light industrial equipment.

- High strength
- High coefficient of friction
- High flexibility
- Lightweight
- Constant thickness
- Inextensible
- Length stable



Trans-flat

Transflat® Standard Belt Thickness 1mm Nominal

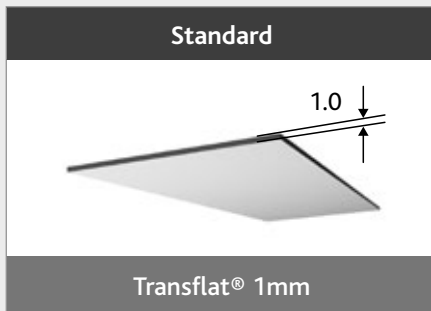

Transflat® length , width & thickness tolerances			
Nominal lengths	Poss. % tolerance	Thickness	Width
330 to 480mm	+/- 2.0%	+/- 0.2mm	+/- 0.5mm
500 to 980mm	+/- 1.5%		
1000 to 3100mm	+/- 1.0%		

As Transflat® belts are endlessly woven nominal lengths can vary between sleeves and therefore drive layouts should allow for the adjustment of centres to provide the requisite drive tension.

Transflat® Standard belt widths (mm)												
10	15	20	25	30	35	40	45	50	60	70	80	90

Transflat® Standard belt lengths (mm)*										
300	450	590	720	880	1060	1250	1450	1710	2020	2500
330	460	600	740	900	1080	1270	1475	1740	2040	2550
340	480	620	760	920	1100	1300	1500	1770	2120	2600
350	500	630	780	940	1120	1320	1530	1800	2160	2750
370	510	650	790	960	1140	1350	1560	1830	2200	2850
385	540	660	800	980	1160	1370	1590	1870	2240	2900
400	550	670	820	1000	1180	1375	1620	1905	2280	2950
420	570	680	840	1020	1220	1400	1650	1940	2320	3100
430	575	700	860	1040	1230	1425	1680	2000	2410	

*As measured under a static tension of 12kg/cm width
Matched sets of belts must be cut from same sleeve. Please specify when ordering.
The initial or static tension of a pulley should correspond to the measuring tension in the above table.

Basic kilowatt ratings (kW per cm/width) with 180° arc of contact																	
Belt speed (m/sec)	Transflat®					Belt speed (m/sec)	Transflat®					Belt speed (m/sec)	Transflat®				
	Small pulley dia. (mm)						Small pulley dia. (mm)						Small pulley dia. (mm)				
	15	20	25	30	>34		15	20	25	30	>34		15	20	25	30	>34
2.5	0.11	0.15	0.17	0.19	0.21	22.5	0.73	1.09	1.36	1.54	1.63	42.5	-	-	-	2.26	2.56
5	0.21	0.29	0.34	0.38	0.4	25	0.78	1.19	1.48	1.69	1.8	45	-	-	-	2.28	2.63
7.5	0.31	0.41	0.5	0.56	0.6	27.5	-	1.28	1.59	1.81	1.95	47.5	-	-	-	2.27	2.66
10	0.39	0.54	0.66	0.74	0.78	30	-	1.35	1.68	1.93	2.09	50	-	-	-	-	2.71
12.5	0.47	0.66	0.82	0.91	0.97	32.5	-	-	1.77	2.02	2.21	52.5	-	-	-	-	2.73
15	0.53	0.78	0.96	1.07	1.14	35	-	-	1.84	2.1	2.31	55	-	-	-	-	2.71
17.5	0.61	0.88	1.11	1.24	1.32	37.5	-	-	1.91	2.17	2.41	57.5	-	-	-	-	2.69
20	0.66	0.99	1.23	1.39	1.49	40	-	-	1.96	2.23	2.5	60	-	-	-	-	2.64



Transflat® Standard Belt Thickness 1mm Nominal

Transflat

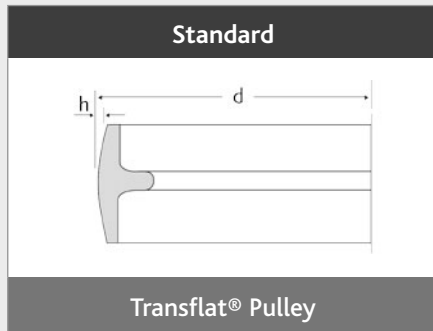

Pulleys should be manufactured from quality materials and be accurate.

It is important to ensure :

- The driving surface of the pulley is perfectly smooth
- The outside diameter of the pulley is concentric to the bore
- Pulleys are well balanced both statically and dynamically
- At least one of the pulleys (driver) should be crowned

Pulley dia. d (mm)	Crown height h (mm)
15	0.3
20	0.3
25	0.3
30	0.3
35	0.3
40	0.3
45	0.3
50	0.3
56	0.3
63	0.3
71	0.3
80	0.3
90	0.3
100	0.3
112	0.3
125	0.4
140	0.4
160	0.5
180	0.5
200	0.6
224	0.6
250	0.8
280	0.8
315	1
355	1

Drive design, belt fitting and tensioning

A drive must be designed to allow for the correct tensioning of the belt and to adjust for any stretch during service (possibly 1.5% of length). A take-up device is therefore required: motor slide bases are the most efficient system for ease of fitting and tensioning the belt.

Idlers may be used to increase arc of contact on high transmission ratios. With contra-flexure, due to the use of idlers, it is recommended that the idler diameters should not be less than the diameter of the small pulley.

The following recommendations should always be followed

- Check that the pulleys are aligned
- Ensure that the pulley surfaces are smooth and well polished
- Apply the correct belt tension
- Check the belt tension frequently during the first few hours of operation
- Do not use any belt grip dressing; the natural belt grip will prevent any slippage if the drive has been properly designed