

# Flange Cartridge Units

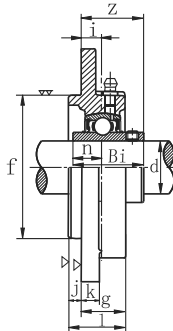

SR type seal

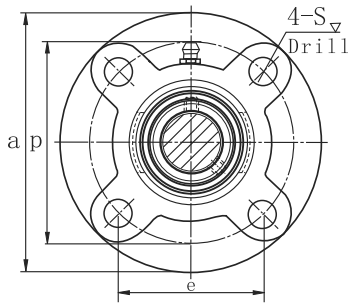
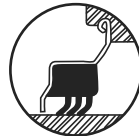

TRL type seal

## UCFC 200

normal-duty

Bearing unit	Shaft Dia.	Dimensions(in)or(mm)														Bolt used	Bearing	Housing Weight	
No.	d	a	p	e	i	l	S	j	k	g	f	Z	Bi	n	No.	No.			
	(in.)	(mm)													(mm)	(in.)	(kg)		
UCFC 201	12	15/16	3/64	2 1/64	25/64	1	15/32	13/64	9/32	13/16	2.4409	1/8	1.2205	0.5000	M10	3/8	UC 201	FC 201	0.78
201-8	1/2	100	78	55.1	10	25.5	12	5	7	20.5	62	28.3	31.0	12.7			201-8		
UCFC 202	15	3 1/16	3 5/64	2 11/64	25/64	1	15/32	13/64	9/32	13/16	2.4409	1/8	1.2205	0.5000	M10	3/8	UC 202	FC 202	0.78
202-10	5/8	100	78	55.1	10	25.5	12	5	7	20.5	62	28.3	31.0	12.7			202-10		
UCFC 203	17	3 15/16	3 5/64	2 11/64	25/64	1	15/32	13/64	9/32	13/16	2.4409	1/8	1.2205	0.5000	M10	3/8	UC 203	FC 203	0.78
203-11	1 1/16	100	78	55.1	10	25.5	12	5	7	20.5	62	28.3	31.0	12.7			203-11		
UCFC 204-12	3/4	15/16	3/64	2 11/64	25/64	1	15/32	13/64	9/32	13/16	2.4409	1/8	1.2205	0.5000	M10	3/8	UC 204-12	FC 204	0.78
204	20	100	78	55.1	10	25.5	12	5	7	20.5	62	28.3	31.0	12.7			204		
UCFC 205-14	7/8	17/32	35/64	2 1/2	25/64	1 1/16	15/32	15/64	9/32	53/64	2.7559	5/32	1.3386	0.5630	M10	3/8	UC 205-14		
205-15	15/16	100	78	55.1	10	27	12	6	7	21	70	29.7	34.0	14.3			205-15		
205	25	115	90	63.6	10	27	12	6	7	21	70	29.7	34.0	14.3			205	FC 205	0.95
205-16	1																205-16		
UCFC 206-18	1 1/8	4 29/32	3 15/16	2 2/32	25/64	7/32	15/32	5/16	5/16	29/32	3.1496	9/32	1.5000	0.6260	M10	3/8	UC 206-18		
206	30	125	100	70.7	10	31	12	8	8	23	80	32.2	38.1	15.9			206		
206-19	3 1/16																206-19	FC 206	1.4
206-20	1 1/4																206-20		
UCFC 207-20	1 1/4	5 1/16	4 21/64	3 1/16	7/16	1 1/32	35/64	5/16	1 1/32	1 1/32	3.5433	1 7/16	1.6890	0.6890	M12	7/16	UC 207-20		
207-21	1 9/16	135	110	77.8	11	34	14	8	9	26	90	36.4	42.9	17.5			207-21		
207-22	1 3/8																207-22	FC 207	1.7
207	35																207		
207-23	1 7/16																207-23		
UCFC 208-24	1 1/2	23/32	23/32	1 1/32	7/16	27/64	35/64	25/64	1 1/32	1 1/32	3.9370	5/8	1.9370	0.7480	M12	7/16	UC 208-24		
208-25	1 9/16	40	145	120	84.8	11	36	14	10	9	26	100	41.2	49.2	19.0		208-25	FC 208	2.0
208	40																208		
UCFC 209-26	1 5/8	6 5/16	5 13/64	4 43/64	25/64	1 1/2	5/8	15/32	9/16	1 1/32	4.1339	1 9/32	1.9370	0.7480	M14	1/2	UC 209-26		
209-27	1 11/16	160	132	93.3	10	38	16	12	14	26	105	40.2	49.2	19.0			209-27		
209-28	1 3/4																209-28	FC 209	2.8
209	45																209		
UCFC 210-30	1 7/8	6 1/2	5 7/16	4 27/32	25/64	9/16	5/8	15/32	9/16	3/32	4.3307	1 1/16	2.0315	0.7480	M14	1/2	UC 210-30		
210-31	1 15/16	50	165	138	97.6	10	40	16	12	14	28	110	42.6	51.6	19.0		210-31	FC 210	3.0
210	50																210		
UCFC 211-32	2	9 7/32	8 29/32	7 11/64	33/64	1 1/16	3/4	15/32	19/32	7/32	4.9213	1 13/16	2.1890	0.8740	M16	5/8	UC 211-32		
211-34	2 1/8	55	185	150	106.1	13	43	19	12	15	31	125	46.4	55.6	22.2		211-34	FC 211	4.0
211																	211		
211-35	2 3/16																211-35		
UCFC 212-36	2 1/4	7 11/16	6 19/64	5 29/64	43/64	7/8	3/4	15/32	19/32	27/64	5.3150	7/32	2.5630	1.0000	M16	5/8	UC 212-36		
212	60	195	160	113.1	17	48	19	12	15	36	135	56.7	65.1	25.4			212		
212-38	2 3/8																212-38	FC 212	4.7
212-39	2 7/16																212-39		
UCFC 213-40	2 1/2	8 1/16	7 11/64	6 47/64	5/8	3 1/32	3/4	35/64	19/32	27/64	5.7087	3/16	2.5630	1.0000	M16	5/8	UC 213-40		
213	65	205	170	120.2	16	50	19	14	15	36	145	55.7	65.1	25.4			213	FC 213	5.4
UCFC 214-44	2 3/4	8 15/32	7 31/32	6 59/64	43/64	1 1/8	3/4	35/64	23/32	1 9/16	5.9055	13/32	2.9370	1.1890	M16	5/8	UC 214-44		
214	70	215	177	125.1	17	54	19	14	18	40	150	61.4	74.6	30.2			214	FC 214	6.8
UCFC 215	75	8 21/32	7 1/4	6 1/8	45/64	7/32	3/4	5/8	23/32	1 9/16	6.2992	15/32	3.0630	1.3110	M16	5/8	UC 215		
215-48	3	220	184	130.1	18	56	19	16	18	40	160	62.5	77.8	33.3			215-48	FC 215	7.3
UCFC 216	80	9 7/16	8 7/8	7 9/16	45/64	9/32	29/32	5/8	23/32	1 1/32	6.6929	21/32	3.2520	1.3110	M20	3/4	UC 216		
216	80	240	200	141.4	18	58	23	16	18	42	170	67.3	82.6	33.3			216	FC 216	8.9
UCFC 217-52	3 1/4	9 27/32	8 3/16	7 51/64	45/64	15/32	29/32	45/64	25/32	25/32	7.0886	3/4	3.3740	1.3425	M20	3/4	UC 217-52		
217	85	250	208	147.1	18	63	23	18	20	45	180	69.6	85.7	34.1			217	FC 217	10.4
UCFC 218-56	3 1/2	10 7/16	9 21/32	8 3/8	55/64	1 1/16	29/32	45/64	25/32	1 1/32	7.4803	3 3/32	3.7795	1.5630	M20	3/4	UC 218-56		
218	90	265	220	155.5	22	68	23	18	20	50	190	78.3	96.0	39.7			218	FC 218	13.0