

Flange Units (Square)

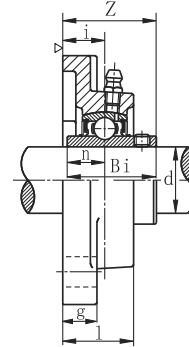

SR type seal

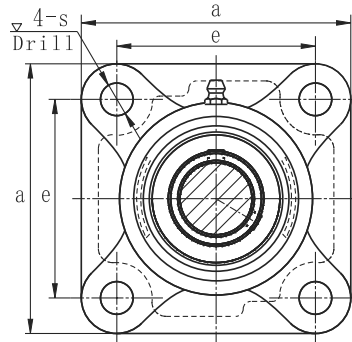

TRL type seal

Bearing unit	Shaft Dia.	Dimensions(in)or(mm)										Bolt used	Bearing	Housing	Weight
No.	d	a	e	i	g	l	s	z	Bi	n		No.	No.		
	(in.) (mm)										(mm) (in.)			(kg)	
UCF X05 X05-16	25 1	4 1/4 108	3 7/64 83	45/64 18	1/2 13	3 1/16 30	15/32 12	1 9/32 40.2	1.5000 38.1	0.6260 15.9	M10 3/8	UC X05 X05-16	FX 05	1.1	
UCF X06 X06-19 X06-20	30 3 3/16 1 1/4	4 19/32 117	5 3/8 92	3/4 19	9/16 14	1 11/32 34	5/8 16	3/4 44.4	1.6890 42.9	0.6890 17.5	M14 1/2	UC X06 X06-19 X06-20	FX 06	1.4	
UCF X07-20 X07-22 X07	35 1 3/4 1 1/8	5 1/8 130	4 1/64 102	53/64 21	9/16 14	1 1/2 38	5/8 16	2 1/32 51.2	1.9370 49.2	0.7480 19.0	M14 1/2	UC X07-20 X07-22 X07	FX 07	1.9	
UCF X08-24 X08	40 1 1/2	5 13/32 137	4 9/64 105	55/64 22	9/16 14	9 9/16 40	3/4 19	2 1/16 52.2	1.9370 49.2	0.7480 19.0	M16 5/8	UC X08-24 X08	FX 08	2.1	
UCF X09-26 X09-27 X09-28 X09	45 1 5/8 1 1/16 1 3/4	5 5/8 143	4 3/8 111	29/32 23	9/16 14	1 9/16 40	3/4 19	2 3/16 55.6	2.0315 51.6	0.7480 19.0	M16 5/8	UC X09-26 X09-27 X09-28 X09	FX 09	2.5	
UCF X10-30 X10-31 X10	50 1 7/8 1 15/16	6 3/8 162	5 1/8 130	1 1/32 26	25/32 20	1 23/32 44	3/4 19	2 11/32 59.4	2.1890 55.6	0.8740 22.2	M16 5/8	UC X10-30 X10-31 X10	FX 10	3.6	
UCF X10-32	2											UC X10-32			
UCF X11 X11-34 X11-35 X11-36	55 2 1/8 2 3/16 2 1/4	6 7/8 175	5 5/8 143	1 9/64 29	25/32 20	1 15/16 49	3/4 19	2 23/32 68.7	2.5630 65.1	1.0000 25.4	M16 5/8	UC X11 X11-34 X11-35 X11-36	FX 11	4.7	
UCF X12-36 X12 X12-38 X12-39	60 2 3/8 2 7/16	7 3/8 187	5 55/64 149	1 11/32 34	13/16 21	2 5/16 59	3/4 19	2 29/32 73.7	2.5630 65.1	1.0000 25.4	M16 5/8	UC X12-36 X12 X12-38 X12-39	FX 12	5.5	
UCF X13-40 X13	65 2 1/2	8 3/8 187	5 55/64 149	1 11/32 34	13/16 21	2 5/16 59	3/4 19	3 3/32 78.4	2.9370 74.6	1.1890 30.2	M16 5/8	UC X13-40 X13	FX 13	5.9	
UCF X14-44 X14	70 2 3/4	9 3/4 197	5 63/64 152	1 29/64 37	15/16 24	2 3/8 60	29/32 23	3 3/32 81.5	3.0630 77.8	1.3110 33.3	M 20 3/4	UC X14-44 X14	FX 14	7.3	
UCF X15 X15-47 X15-48	75 2 15/16 3	10 3/4 197	5 63/64 152	1 37/64 40	15/16 24	2 11/16 68	29/32 23	3 17/32 89.3	3.2520 82.6	1.3110 33.3	M 20 3/4	UC X15 X15-47 X15-48	FX 15	8.0	
UCF X16 X16-50	80 3 1/8	10 7/16 214	6 47/64 171	1 37/64 40	15/16 24	2 3/4 70	29/32 23	3 19/32 91.6	3.3740 85.7	1.3425 34.1	M 20 3/4	UC X16 X16-50	FX 16	9.8	
UCF X17 X17-52	85 3 1/4	11 7/16 214	6 47/64 171	1 37/64 40	15/16 24	2 3/4 70	29/32 23	3 25/32 96.3	3.7795 96.0	1.5630 39.7	M 20 3/4	UC X17 X17-52	FX 17	10.5	
UCF X18-56 X18	90 3 1/2	12 7/16 214	6 47/64 171	1 49/64 45	15/16 24	3 76	29/32 23	4 3/16 106.1	4.0945 104.0	1.6890 42.9	M 20 3/4	UC X18-56 X18	FX 18	11.2	
UCF X20 X20-64	100 4	12 9/16 268	8 5/16 211	2 27/64 59	1 1/32 31	3 13/16 97	1 1/32 31	5 3/250 127.3	4.6260 117.5	1.9370 49.2	M 27 1	UC X20 X20-64	FX 20	18.1	