

Metric Moulded Mitre Gear Sets, HOSTAFORM® C, 0.5 - 3.5 MOD

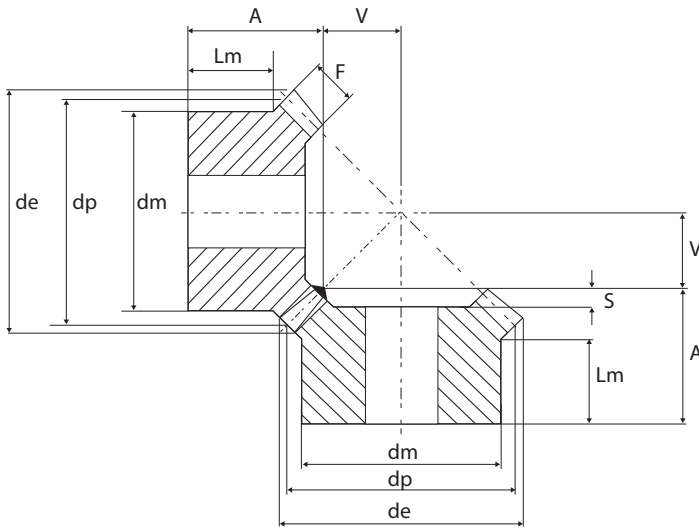

Metric Mitre Gear Set



- Intermediate sizes and special mitres to drawing (tooling charges may apply)
- DIN 3962, 3963, 3967 grade 12
- Shaft axis to intersect within +/- 0.025mm
- Angular accuracy between shafts +/- 5mins
- Mounting distance tolerance +/- 0.05mm
- Bore tolerance H9
- Max. recommended working temperature 90°C
- Cut to the Gleason System
- 20° pressure angle
- Supplied in pairs
- All dimensions in mm
- White HOSTAFORM® C

HOSTAFORM®

Code	Pitch module	No. teeth	dp (mm)	de (mm)	dm (mm)	Bore	F (mm)	Lm (mm)	A (mm)	V+A (mm)	S (mm)
WPBM05/16	0.5	16	8	8.7	7	3	2	6	8	10.5	0
WPBM10/16	1	16	16	17.6	12	5	4.7	8	13.6	18.4	0
WPBM10/30	1	30	30	31.4	15	6	7.4	7.4	15.3	24.8	2.4
WPBM15/16	1.5	16	24	26.4	18.5	8	7	10	18.4	25.8	2.2
WPBM20/16	2	16	32	34.9	21.9	10	10	9.6	21.2	30.4	2.9
WPBM25/16	2.5	16	40	43.5	25.2	12	12	11.5	25.5	37.0	2.6
WPBM30/16	3	16	48	52.3	28.8	14	14	13.2	29.2	43	2.4
WPBM35/16	3.5	16	56	61.4	33.3	18	16	14.4	33.1	49.5	5

Please note: All dimensions subject to change. If a dimension is critical to your application please contact our Sales Department for confirmation. For special or reworked gears please contact our Manufacturing Department for a quotation.